

# GOLD'S GYM® Pro Series



Model No. GGBE8057.0

Serial No. \_\_\_\_\_

Write the serial number in the space above for future reference.

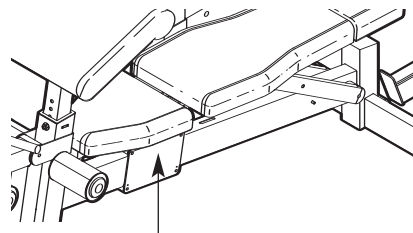

Serial Number Decal (under seat)

## USER'S MANUAL

### QUESTIONS?

As a manufacturer, we are committed to providing complete customer satisfaction. If you have questions, or if a part is damaged or missing, PLEASE CONTACT OUR CUSTOMER SERVICE DEPARTMENT DIRECTLY.

CALL TOLL-FREE:

**1-877-776-4777**

Mon.–Fri. 6 a.m.–6 p.m. MST

Sat. 8 a.m.–4 p.m. MST

ON THE WEB:

[www.goldsgympowerflex.com](http://www.goldsgympowerflex.com)

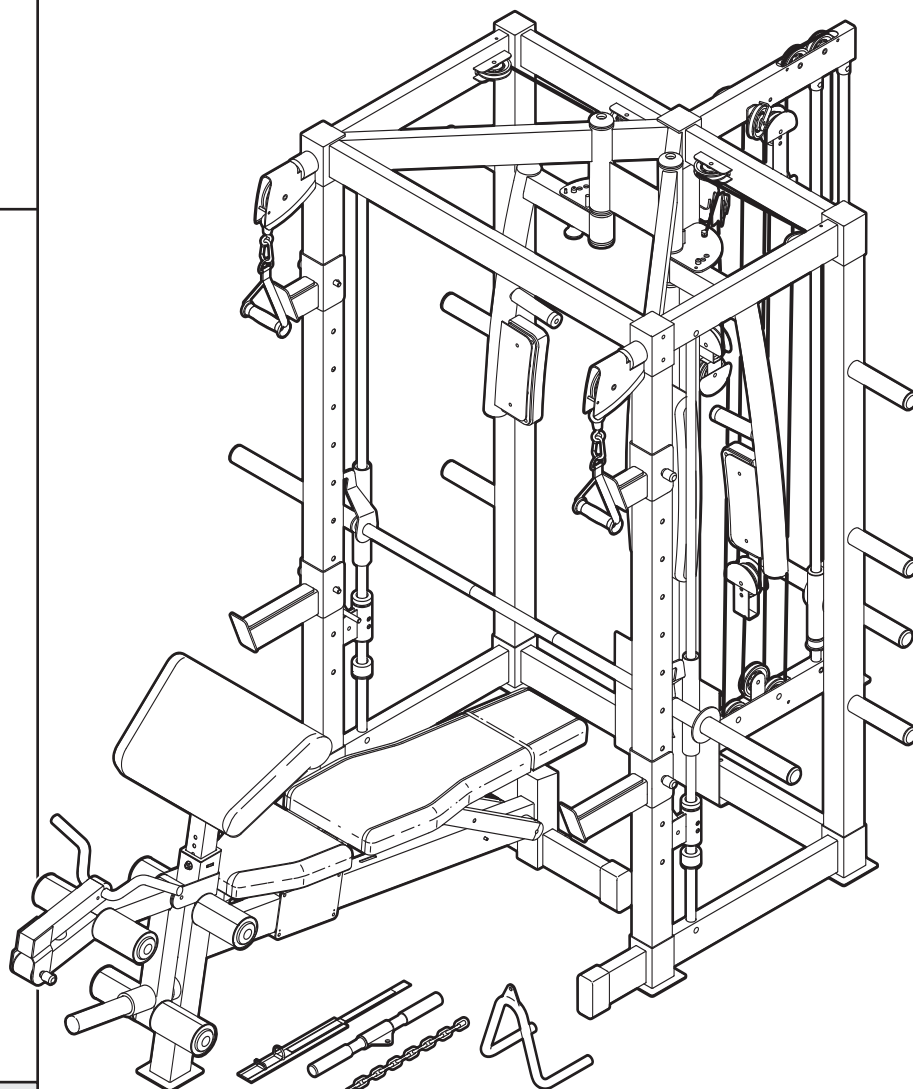

### CAUTION

Read all precautions and instructions in this manual before using this equipment. Save this manual for future reference.

# TABLE OF CONTENTS

WARNING DECAL PLACEMENT .....	2
IMPORTANT PRECAUTIONS .....	3
BEFORE YOU BEGIN .....	4
PART IDENTIFICATION CHART .....	5
ASSEMBLY .....	7
ADJUSTMENT .....	29
MAINTENANCE .....	33
CABLE DIAGRAM .....	34
EXERCISE GUIDELINES .....	35
PART LIST .....	38
EXPLODED DRAWING .....	40
ORDERING REPLACEMENT PARTS .....	Back Cover
LIMITED WARRANTY .....	Back Cover

## WARNING DECAL PLACEMENT

The decals shown here have been applied to the weight bench. **If a decal is missing or illegible, call the telephone number on the front cover of this manual and request a free replacement decal. Apply the decal in the location shown.** Note: The decals may not be shown at actual size.

**⚠ WARNING**

User Weight: Max 300 LBS  
 Weight Crutch: Max 310 LBS  
 Leg Developer: Max 150 LBS  
 Weight Carriage: Max 150 LBS  
 Chest Fly Per Arm: Max 50 LBS

Product may not offer all listed exercises.

**⚠ WARNING**

- Misuse of this machine may result in serious injury.
- Read user's manual prior to use and follow all warnings and instructions.
- Do not allow children on or around machine.
- Keep body, clothing, and hair free and clear of all moving parts.
- Replace label if damaged, illegible, or removed.

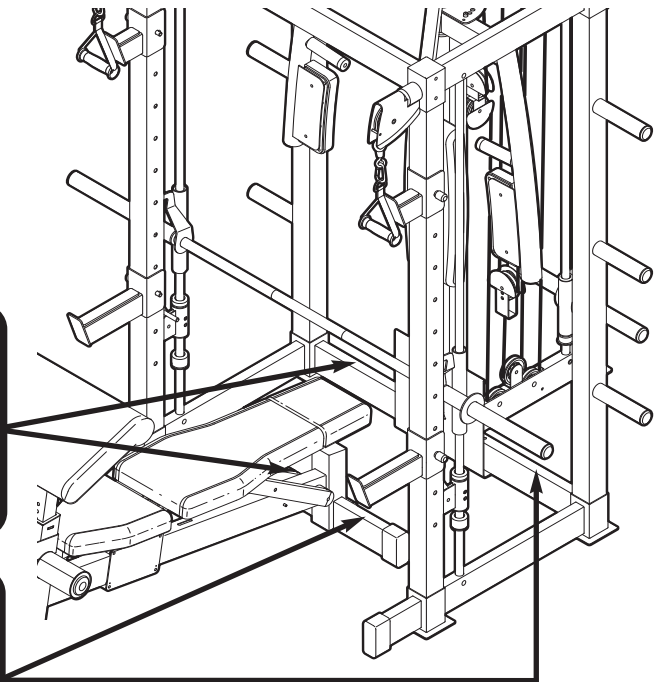

# IMPORTANT PRECAUTIONS

**⚠️ WARNING:** To reduce the risk of serious injury, read all important precautions and instructions in this manual and all warnings on the weight bench before using the weight bench. ICON assumes no responsibility for personal injury or property damage sustained by or through the use of the weight bench.

1. Before beginning any exercise program, consult your physician. This is especially important for persons over the age of 35 or persons with pre-existing health problems.
2. Read all instructions in this manual and all warnings on the weight bench before using the weight bench.
3. It is the responsibility of the owner to ensure that all users of the weight bench are adequately informed of all precautions.
4. The weight bench is intended for home use only. Do not use the weight bench in a commercial, rental, or institutional setting.
5. Keep the weight bench indoors, away from moisture and dust. Place the weight bench on a level surface, with a mat beneath it to protect the floor or carpet. Make sure that there is enough clearance around the weight bench to mount, dismount, and use it.
6. Keep children under age 12 and pets away from the weight bench at all times.
7. Inspect and properly tighten all parts regularly. Replace any worn parts immediately.
8. Make sure that the pins and knobs are fully engaged before the weight bench is used.
9. Wear appropriate clothes while exercising. Always wear athletic shoes for foot protection while exercising.
10. The weight bench is designed to support a maximum user weight of 300 lbs. (136 kg) and a maximum total weight of 610 lbs. (277 kg). Do not place more than 310 lbs. (141 kg), including a barbell, on the weight rests. Do not place more than 150 lbs. (68 kg) on the leg lever. Do not place more than 150 lbs. (68kg) on the weight carriage. Note: The weight bench does not include weights.
11. Make sure that the cables remain on the pulleys at all times. If the cables bind as you are exercising, stop immediately and make sure that the cables are on the pulleys. Replace all cables at least every two years.
12. Always set all the weight rests and safety spotters at the same height.
13. Always place an equal amount of weight on each side of the weight carriage or barbell.
14. Always exercise with a partner. Your partner should be ready to catch the barbell if you cannot complete a repetition.
15. Always disconnect the lat bar when performing an exercise that does not require the lat bar.
16. If you feel pain or dizziness while exercising, stop immediately and cool down.
17. Use the weight bench only as described in this manual.

# BEFORE YOU BEGIN

Thank you for selecting the versatile GOLD'S GYM® PRO SERIES weight bench. The weight bench offers an impressive selection of exercise stations designed to develop every major muscle group of the body. Whether your goal is to tone your body, build dramatic muscle size and strength, or improve your cardiovascular system, the weight bench will help you to achieve the specific results you want.

manual. To help us assist you, note the product model number and serial number before contacting us. The model number and the location of the serial number decal are shown on the front cover of this manual.

**To avoid a registration fee for any service needed under warranty, you must register the weight bench at [www.iconservice.com/registration](http://www.iconservice.com/registration).**

**For your benefit, read this manual carefully before using the weight bench.** If you have questions after reading this manual, please see the front cover of this

Before reading further, please review the drawing below and familiarize yourself with the parts that are labeled.

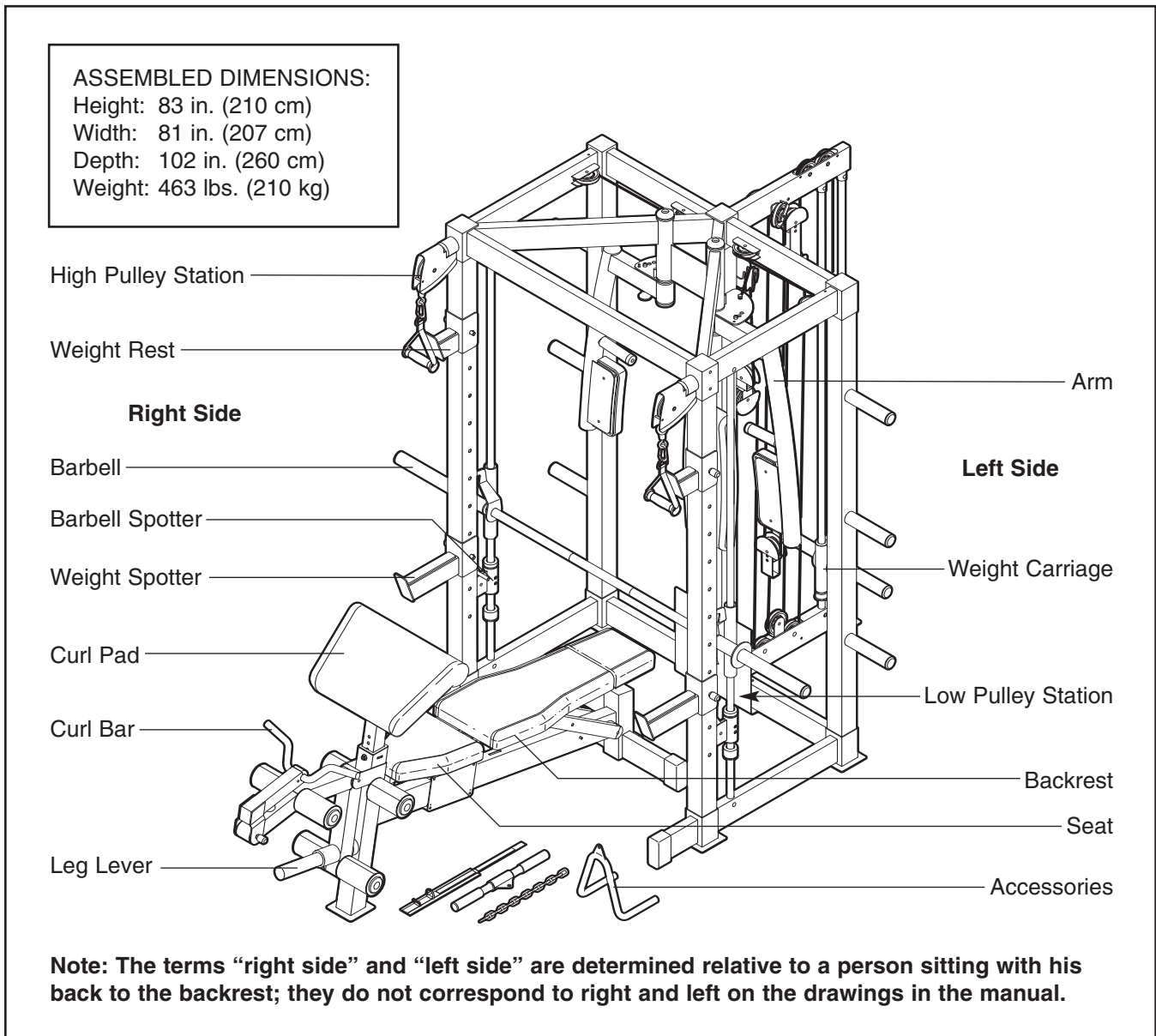

# PART IDENTIFICATION CHART

See the drawings below to identify small parts used in assembly. The number in parentheses by each drawing is the key number of the part, from the PART LIST near the end of this manual. **Note: Some small parts may have been preattached. If a part is not in the parts bag, check to see if it has been preattached.**

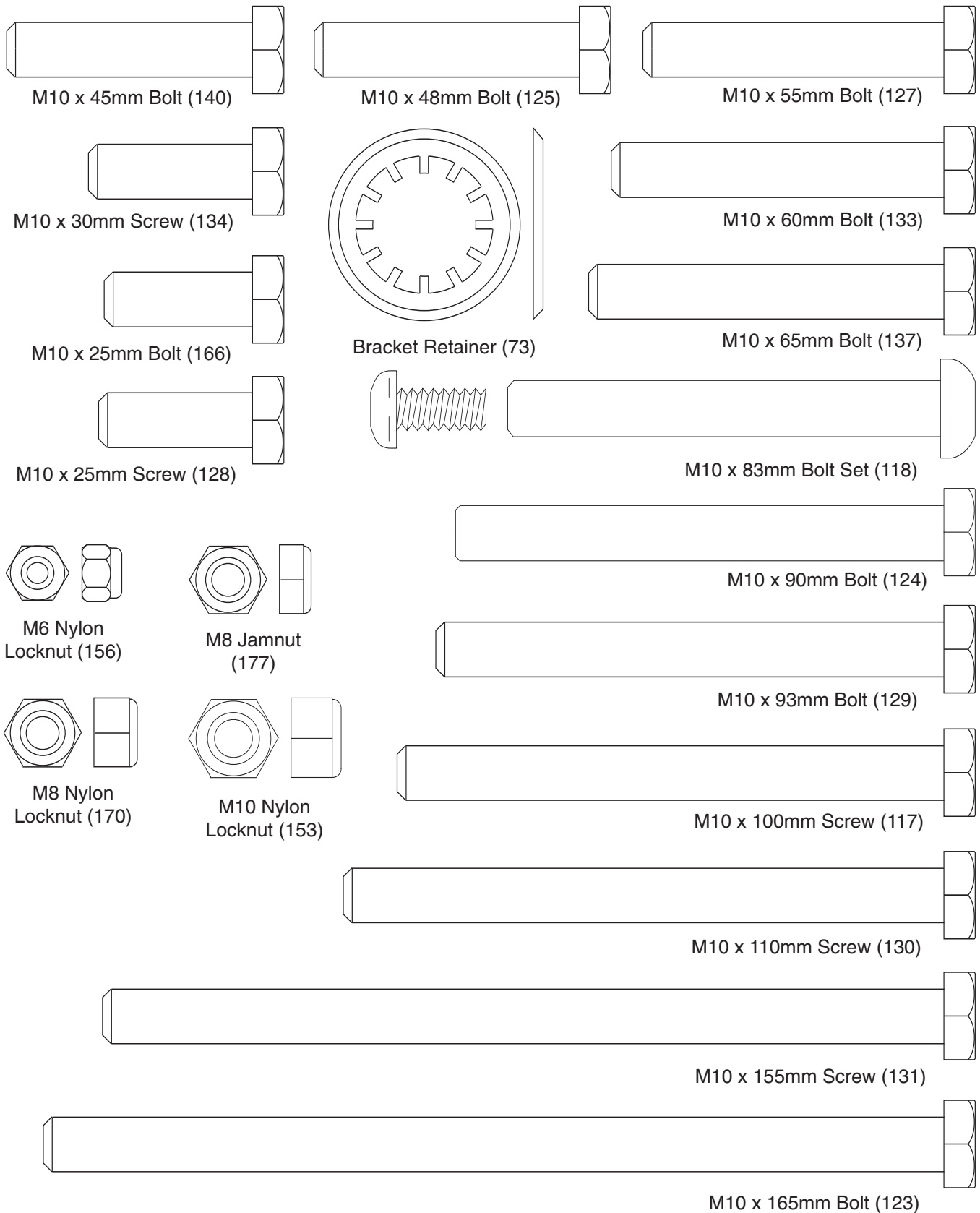



Curl Bar Spacer (178)

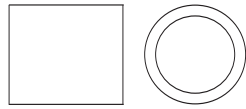

13mm x 15mm Spacer (154)



13mm x 63mm Spacer (54)



Backrest Support Spacer (51)

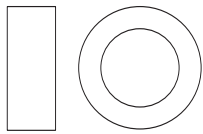

M10 x 6.5mm  
Spacer (151)

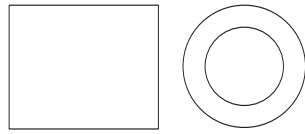

M10 x 20mm  
Spacer (150)

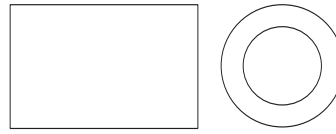

M10 x 25mm  
Spacer (169)

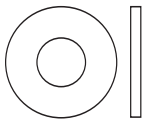

M6 Washer (149)

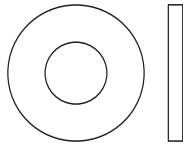

M8 Washer (164)



M10 Lock Washer (86)

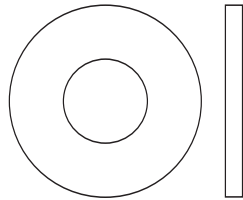

M10 Washer (148)

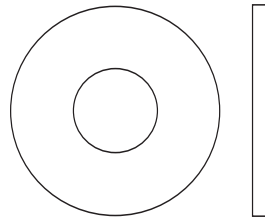

M10 Large Washer (171)

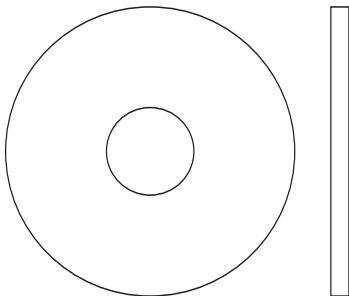

Large Washer (135)

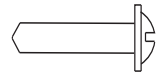

M4 x 16mm Self-tapping Screw (147)

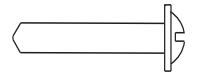

M4 x 20mm Self-tapping Screw (120)

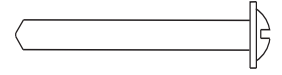

M4 x 30mm Self-tapping Screw (79)

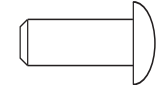

M6 x 15mm Bolt (144)

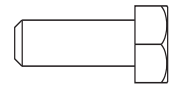

M6 x 16mm Screw (141)

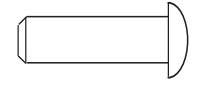

M6 x 20mm Screw (122)

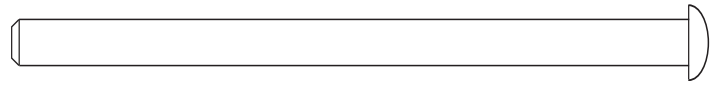

M6 x 90mm Screw (126)

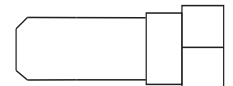

M8 x 22mm Shoulder Bolt (143)

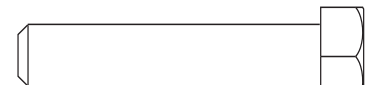

M8 x 40mm Bolt (136)



M8 x 65mm Bolt (146)



M8 x 90mm Bolt (172)

# ASSEMBLY

## Make Assembly Easier

Everything in this manual is designed to ensure that the weight bench can be assembled successfully by almost anyone. By setting aside plenty of time, assembly will go smoothly.

Before beginning assembly, carefully read the following information and instructions:

- To hire an authorized service technician to assemble the weight bench, call 1-800-445-2480.
- Assembly requires two persons. Some steps may require three persons.
- Because of its size, the weight bench should be assembled in the location where it will be used. Make sure that there is enough clearance to walk around the weight bench as you assemble it.
- Place all parts in a cleared area and remove the

packing materials. Do not dispose of the packing materials until assembly is completed.

- Tighten all parts as you assemble them, unless instructed to do otherwise.
- As you assemble the weight bench, make sure all parts are oriented as shown in the drawings.
- For help identifying small parts, use the PART IDENTIFICATION CHART on page 5.
- In addition to the included tools, assembly requires the following tools (not included):

two adjustable wrenches



one rubber mallet



one standard screwdriver



one Phillips screwdriver



Some assembly steps also require a socket set with an extension.

1.

**Before beginning assembly, read the important information in the box above. See the PART IDENTIFICATION CHART on page 5 for help identifying small parts.**

Orient the Rear Leg (2) so that the Transport Wheel (46) is on the side shown. Attach the Rear Leg to the Bench Frame (1) with two M10 x 100mm Screws (117) and two M10 Washers (148). **Do not tighten the Screws yet.**

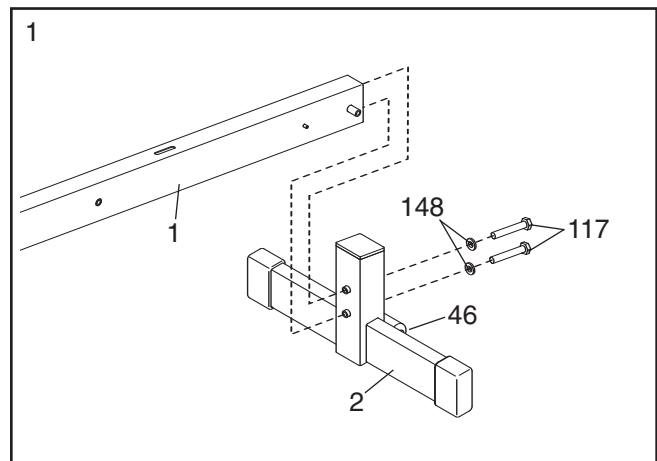

2. Orient the Seat Carriage (6) as shown, and slide it onto the Bench Frame (1).

Tighten the Seat Knob (56) into the Seat Carriage (6). Next, pull the Seat Knob, slide the Seat Carriage to the desired position, and engage the Seat Knob into one of the holes in the Bench Frame (1).

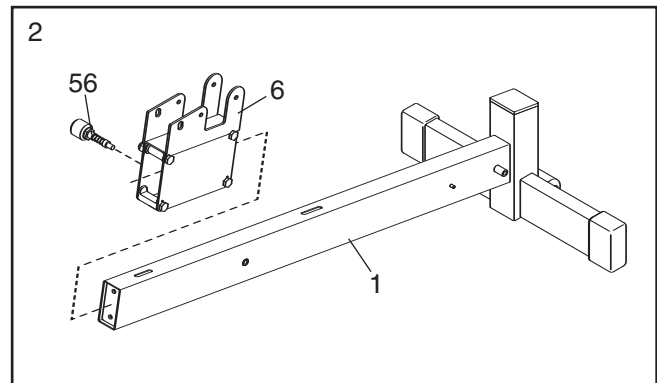

- Attach the Front Leg (3) to the Bench Frame (1) with two M10 x 100mm Screws (117) and two M10 Washers (148). **Tighten the Screws used in steps 1 and 3.**

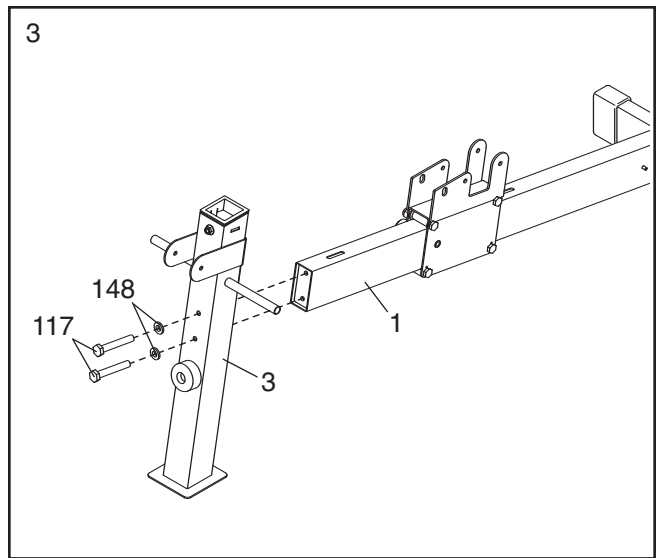

- Attach the Backrest (32) and the Headrest (99) to the Backrest Frame (8) with six M6 x 20mm Screws (122).

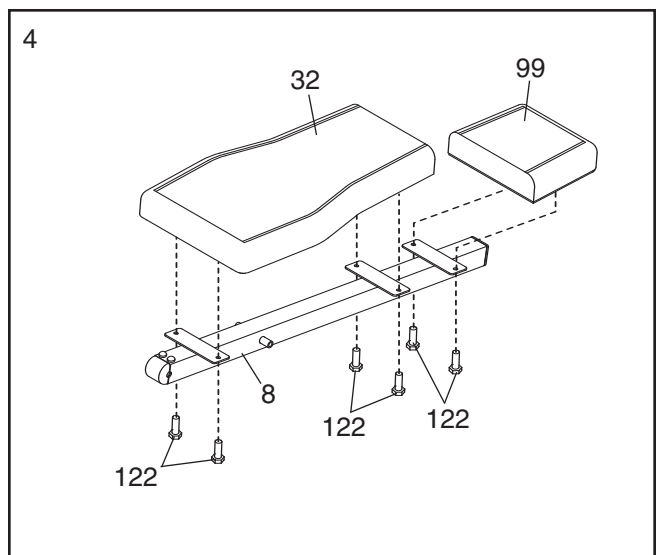

- Attach the Backrest Support Spacer (51) between the two Backrest Supports (7) with an M10 x 165mm Bolt (123), two M10 Washers (148), and an M10 Nylon Locknut (153). **Do not tighten the Nylon Locknut yet.**

Orient the Backrest Supports (7) so that the Backrest Support Spacer (51) is closer to the upper ends.

Apply some of the included grease to an M10 x 165mm Bolt (123). Attach the Backrest Frame (8) and two Backrest Bushings (48) between the Backrest Supports with the Bolt, two M10 Washers (148), and an M10 Nylon Locknut (153). **Do not overtighten the Nylon Locknut; the Backrest Supports must pivot easily.**

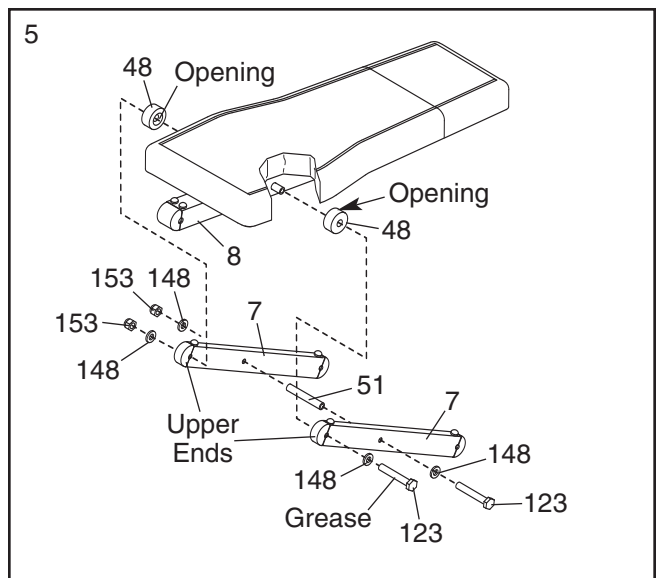



6. Grease an M10 x 165mm Bolt (123). Attach the Backrest Supports (7) and two Backrest Bushings (48) to the Bench Frame (1) with the Bolt, two M10 Washers (148), and an M10 Nylon Locknut (153). **Do not overtighten the Nylon Locknut; the Backrest Supports must pivot easily.**

Insert a 13mm x 63mm Spacer (54) into the Backrest Frame (8). Grease an M10 x 90mm Bolt (124). Attach the Backrest Frame (8) to the Seat Carriage (6) with the Bolt, two 19mm x 6mm Spacers (155), and an M10 Nylon Locknut (153). **Do not overtighten the Nylon Locknut; the Backrest Frame must pivot easily.**

**See step 5. Tighten the two M10 Nylon Locknuts (153).**

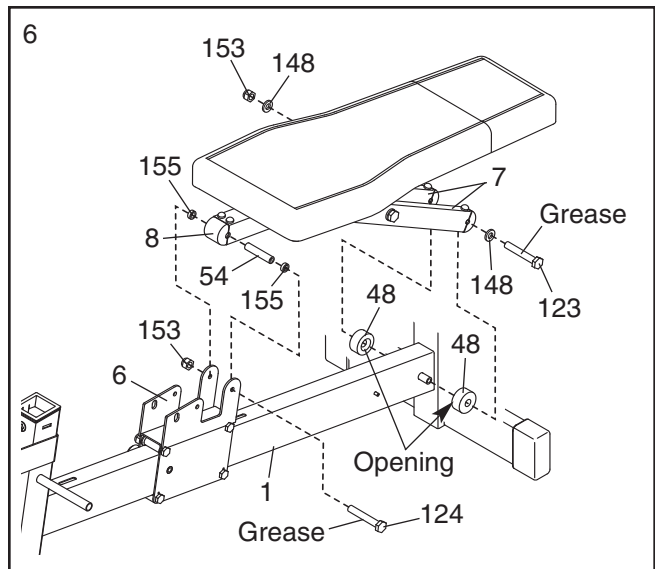

7. Attach the Seat (33) to the Seat Frame (9) with two M6 x 20mm Screws (122).

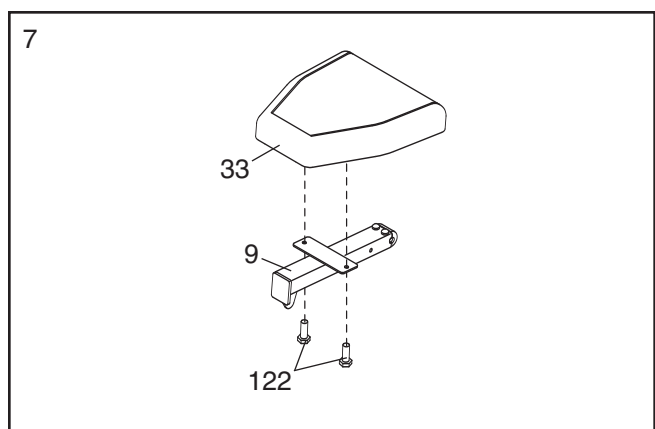

8. Insert a 13mm x 63mm Spacer (54) into the Seat Frame (9). Grease an M10 x 90mm Bolt (124). Attach the Seat Frame (9) to the Seat Carriage (6) with the Bolt, two 19mm x 6mm Spacers (155), and an M10 Nylon Locknut (153). **Do not tighten the Nylon Locknut yet.**

**See the inset drawing.** Grease an M8 x 90mm Bolt (172). Attach the Bolt, two 13mm x 15mm Spacers (154), and an M8 Nylon Locknut (170) to the Seat Carriage (6) and the Seat Frame (9). **Tighten both Nylon Locknuts used in this step. Do not overtighten the Nylon Locknuts; the Seat Frame must pivot easily.**

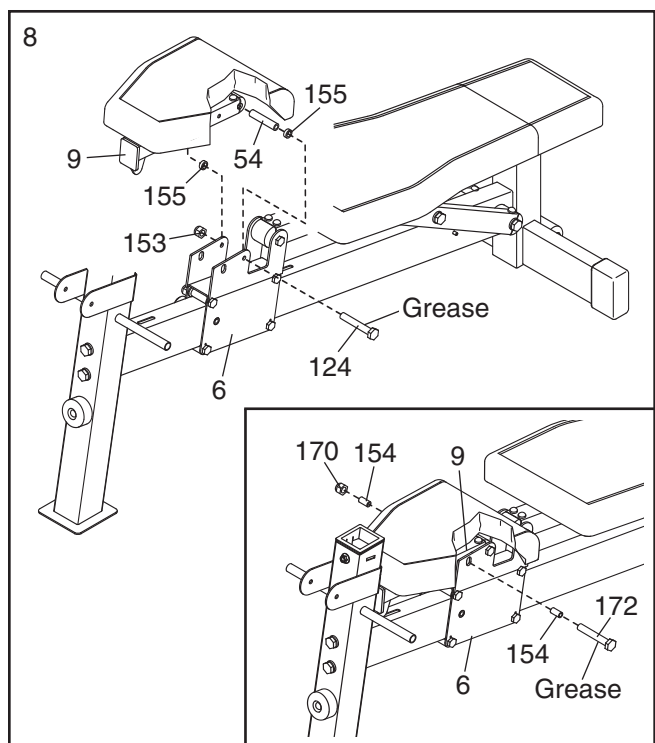

- Slide the Weight Spacer (160) onto the Leg Lever (4).

Grease the outside of the barrel of an M10 x 83mm Bolt Set (118). Attach the Leg Lever (4) to the Front Leg (3) with the Bolt Set. **Make sure that the barrel of the Bolt Set is inserted through both sides of the bracket on the Leg Lever.**

Attach the Curl Bar Pin/Tether (36) to the Leg Lever (4) with an M4 x 16mm Self-tapping Screw (147).

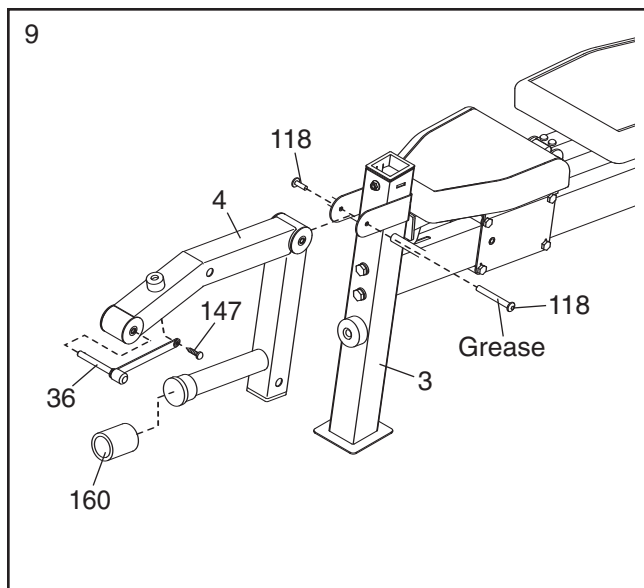

- Slide two Foam Pads (35) onto the Front Leg (3). Then, press two Pad Caps (37) into the Foam Pads.

Insert the two Pad Tubes (159) into the Leg Lever (4). Slide two Foam Pads (35) onto each Pad Tube. Then, press a Pad Cap (37) into each Foam Pad.

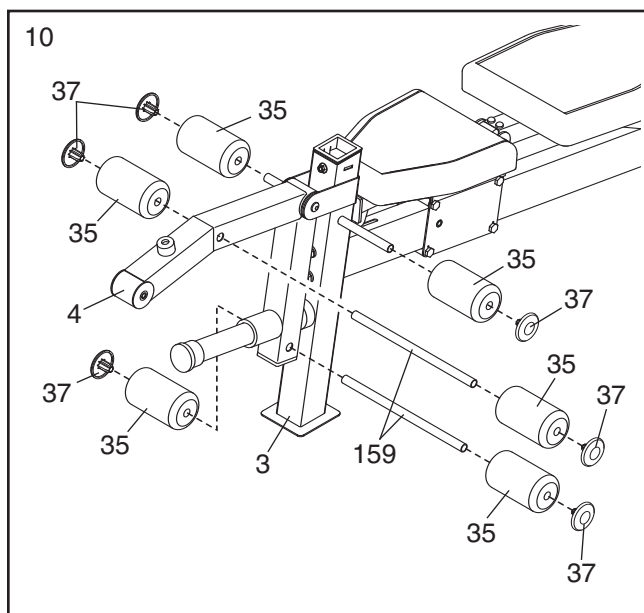

- Insert the Curl Bar (40) into the 50mm x 1.5mm Connecting Cap (42) as shown. Next, tighten an M4 x 30mm Self-tapping Screw (79) with a Curl Bar Spacer (178) into the slot in the Connecting Cap and into the hole in the Curl Bar.

Attach the 50mm x 1.5mm Connecting Cap (42) to the Curl Bar Frame (5) with an M8 x 65mm Bolt (146), two M8 Washers (164), and an M8 Nylon Locknut (170).

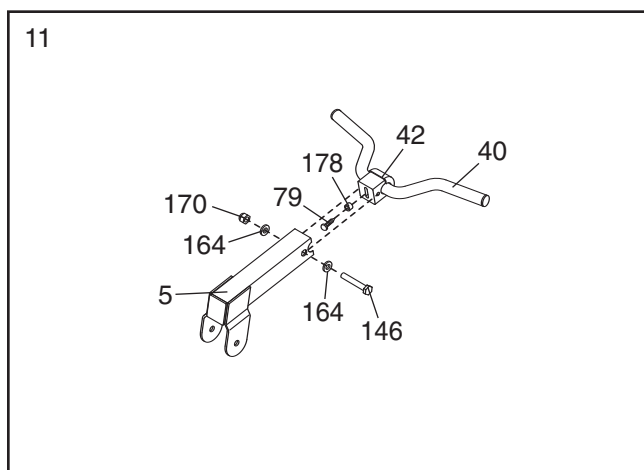

12. Attach the Curl Pad (34) to the Curl Post (10) with two M6 x 20mm Screws (122).

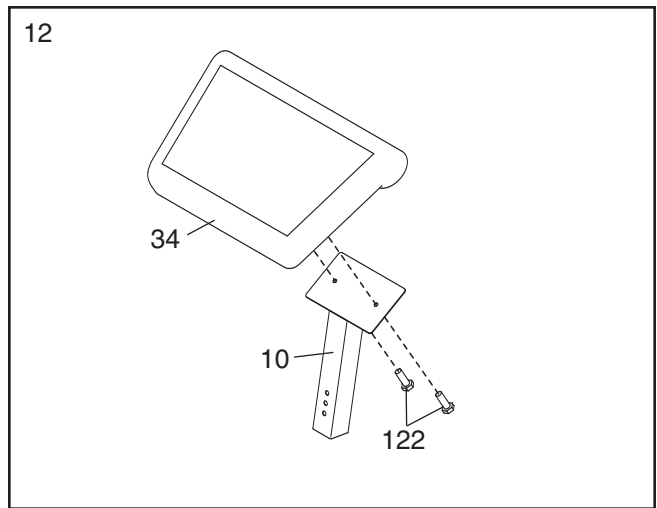

13. Orient one of the Front Uprights (11) and one of the Base Feet (16) as shown. Attach the Front Upright and the Base Foot to the Base (14) with two M10 x 155mm Screws (131). Then, orient a 38mm x 100mm Large Outer Cap (180) so that the thick end is at the bottom (see the inset drawing), and press it onto the Base Foot.

**Attach the other Front Upright (11), Base Foot (16), and 38mm x 100mm Large Outer Cap (180) in the same way.**

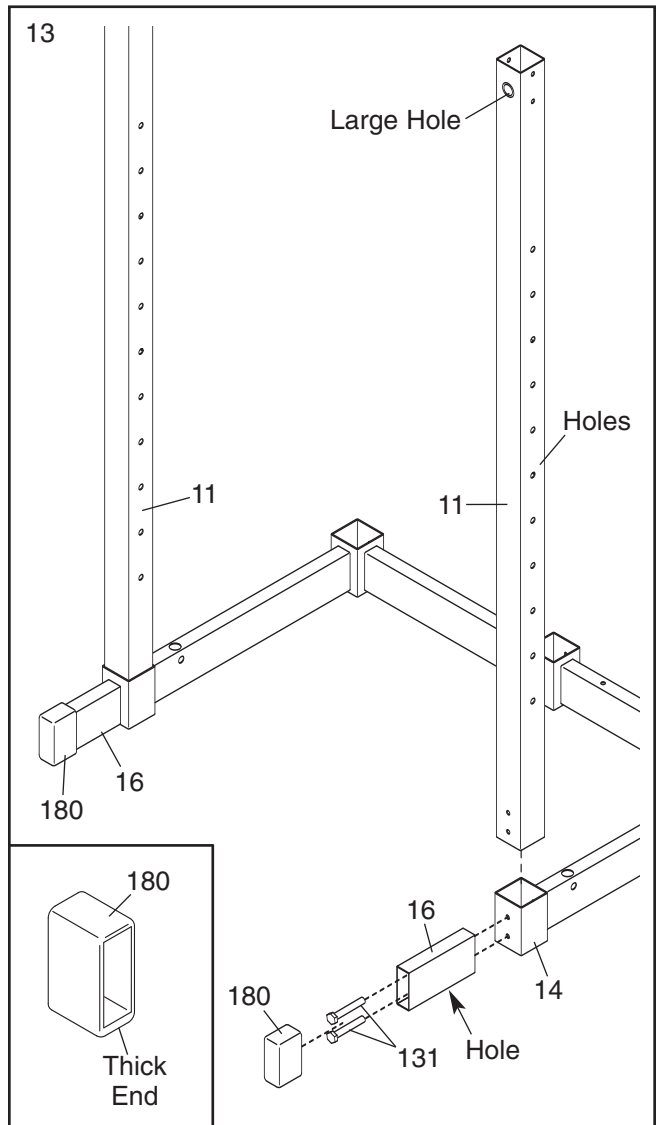

14. Orient a Rear Upright (12) as shown. Attach the Rear Upright to the Base (14) with two M10 x 110mm Screws (130) and two M10 Washers (148). **Do not tighten the Screws yet.**

**Attach the other Rear Upright (12) to the Base (14) in the same way.**

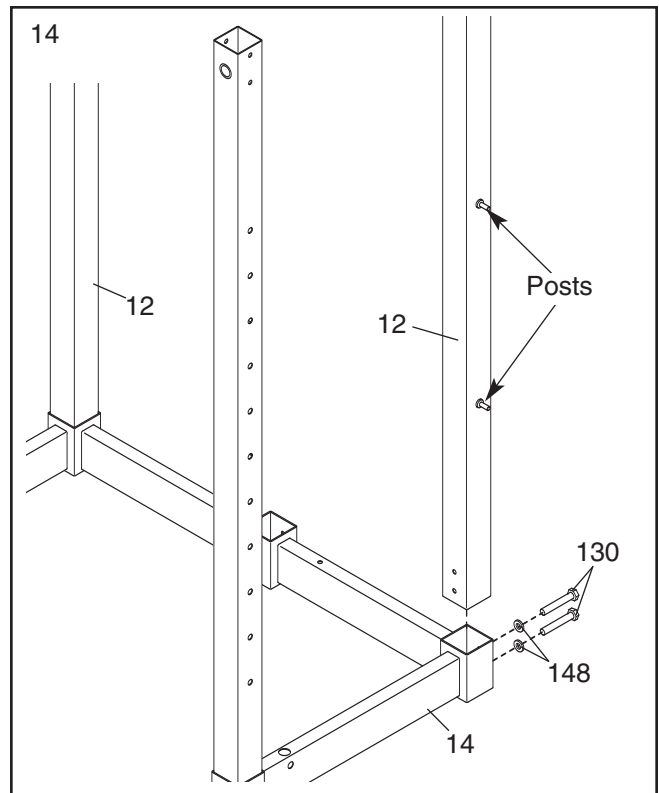

15. Attach a Floor Guard (78) to the the Base (14) with two M4 x 20mm Self-tapping Screws (120).

**Attach the remaining three Floor Guards (78) to the Base (14) in the same way.**

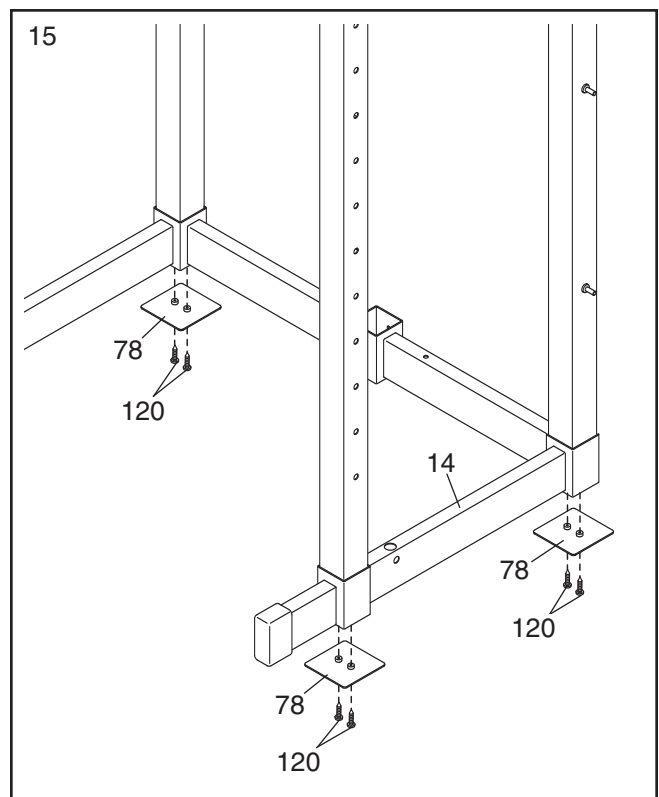

16. Orient the Center Upright (13) as shown and insert it into the Base (14). Hold the Foot Plate (15) and the Weight Carriage Base (20) against the Base. Attach the Foot Plate, Center Upright, and Weight Carriage Base to the Base with two M10 x 110mm Screws (130). **Do not tighten the Screws yet.**

Attach the Foot Plate (15) to the Center Upright (13) with an M10 x 93mm Bolt (129), an M10 Washer (148), and an M10 Nylon Locknut (153).

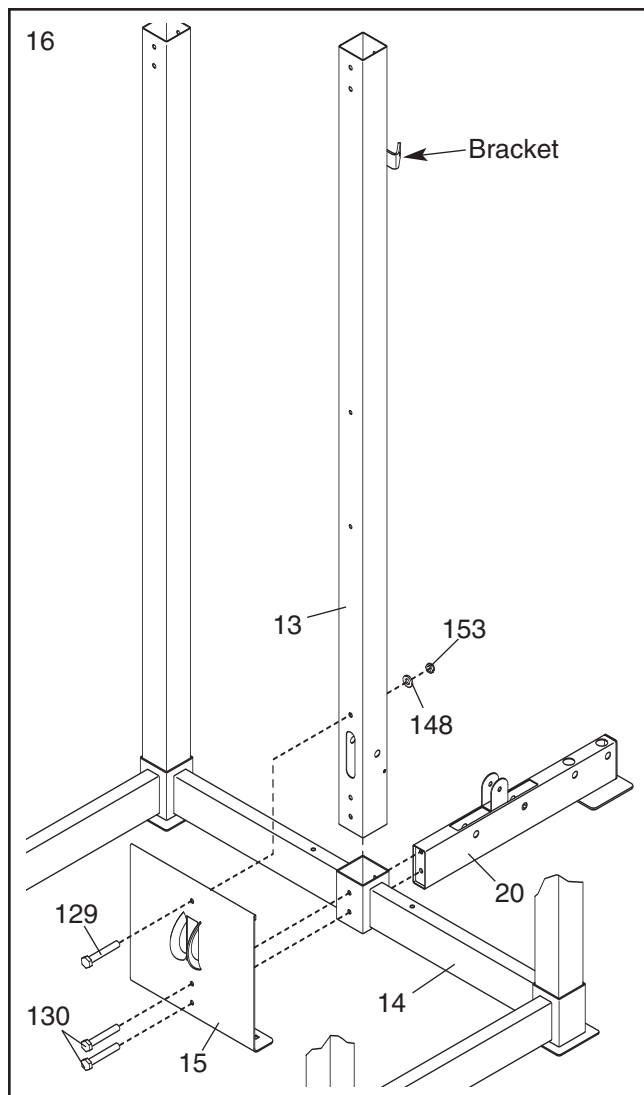

17. Attach the Top Frame (17) to the Rear Uprights (12) with four M10 x 110mm Screws (130) and four M10 Washers (148). **Do not tighten the Screws yet.**

**Attach the Top Frame (17) to the Front Uprights (11) in the same way.**

Press four 75mm Square Inner Caps (95) into the corners of the Top Frame (17).

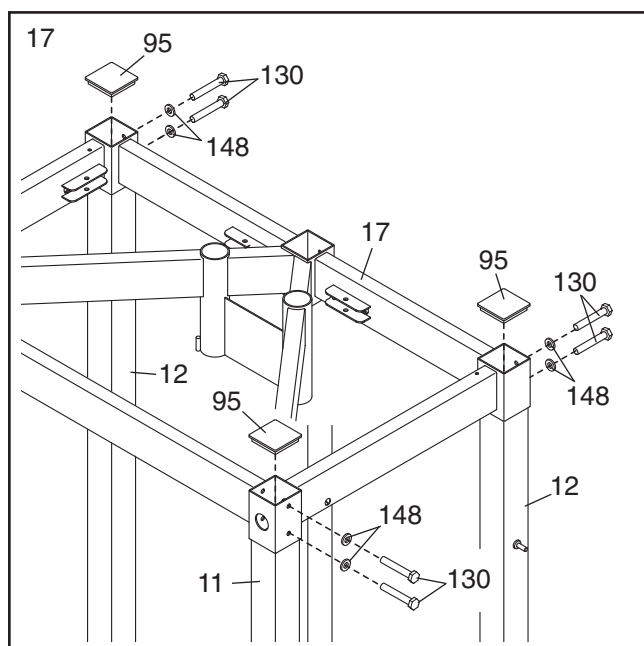

18. Attach the Left Spotter Hook (115) to a Barbell Spotter (109) with an M10 x 25mm Bolt (166) and an M10 Nylon Locknut (153). **Do not overtighten the Nylon Locknut; the Left Spotter Hook must pivot easily.**

Identify a Barbell Guide (112), which is slightly shorter than a Weight Carriage Guide (not shown). Slide a Barbell Spotter Bumper (111) and the Barbell Spotter (109) onto the Barbell Guide.

Orient a Barbell Carriage (104) as shown. Slide a Barbell Bumper (107) and the Barbell Carriage onto the Barbell Guide (112).

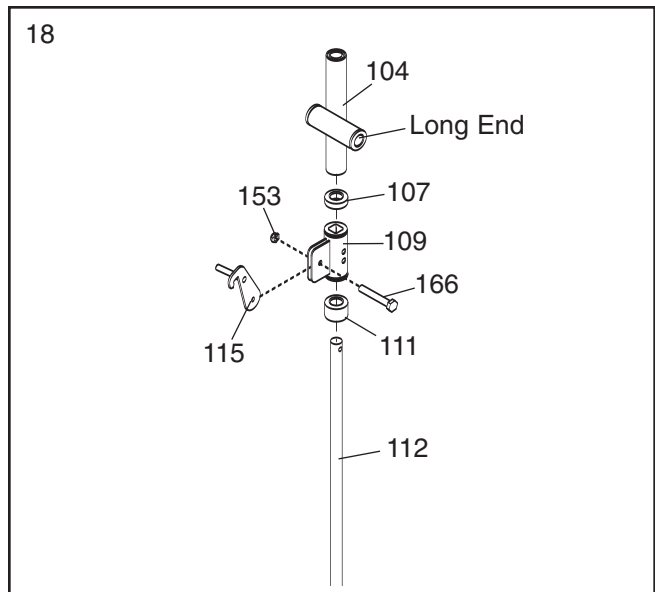

19. Insert the Barbell Guide (112) into the indicated hole in the Base (14). Next, lift the Barbell Guide up into the hole in the Top Frame (not shown). Attach the Barbell Guide to the Base with an M10 x 55mm Bolt (127), two M10 Washers (148), two M10 x 6.5mm Spacers (151), and an M10 Nylon Locknut (153).

Engage the Left Spotter Hook (115) into an adjustment slot near the bottom of the Front Upright (11).

**Repeat steps 18 and 19 with the other Barbell Guide (not shown). Always position both Barbell Spotters (109) at the same height.**

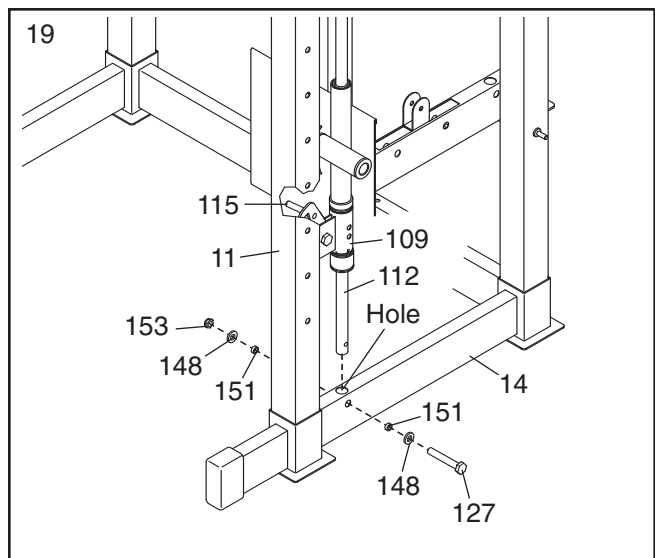

20. Attach a Barbell Guide (112) to the Top Frame (17) with an M10 x 55mm Bolt (127), two M10 Washers (148), two M10 x 6.5mm Spacers (151), and an M10 Nylon Locknut (153).

**Attach the other Barbell Guide (not shown) to the Top Frame (17) in the same way.**

**See steps 14, 16, and 17. Tighten the M10 x 110mm Screws (130).**

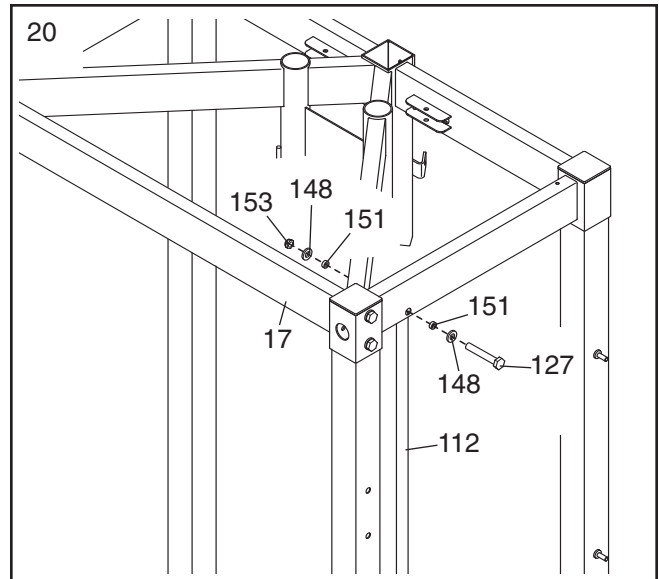

21. Attach a Weight Carriage Guide (21) to the Weight Carriage Base (20) with an M10 x 55mm Bolt (127), two M10 Washers (148), two M10 x 6.5mm Spacers (151), and an M10 Nylon Locknut (153). **Do not tighten the Nylon Locknut yet.**

**Attach the other Weight Carriage Guide (21) to the Weight Carriage Base (20) in the same way.**

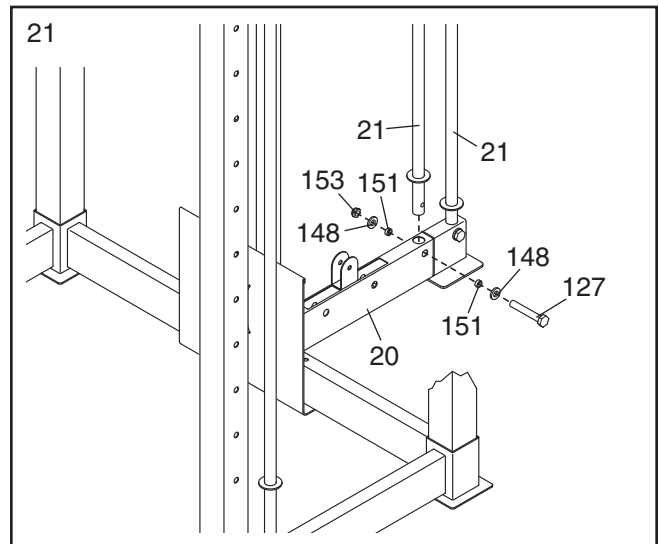

22. Slide the two Weight Carriage Bumpers (138) onto the Weight Carriage Guides (21).

Orient the Weight Carriage (19) as shown, and slide it onto the Weight Carriage Guides (21). Tighten the two Weight Carriage Tubes (96) onto the Weight Carriage. Next, slide the Weight Bumpers (97) onto the Weight Carriage Tubes.

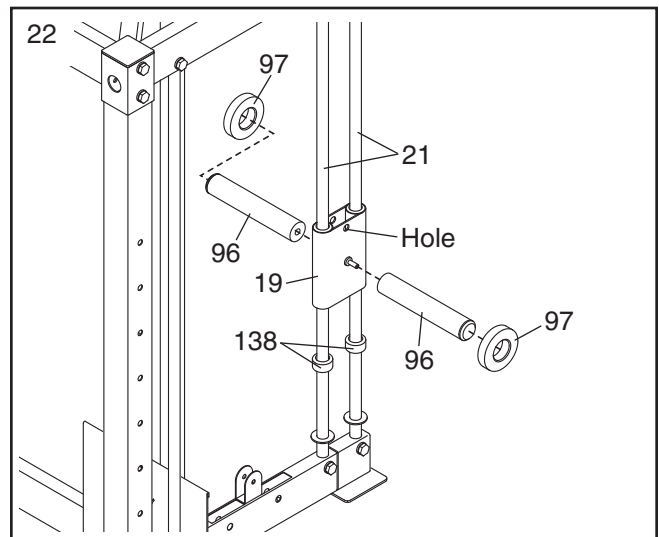

23. Attach the Weight Carriage Frame (18) to the Weight Carriage Guides (21) with two M8 x 40mm Bolts (136) and two M8 Nylon Locknuts (170). **Do not tighten the Nylon Locknuts yet.**

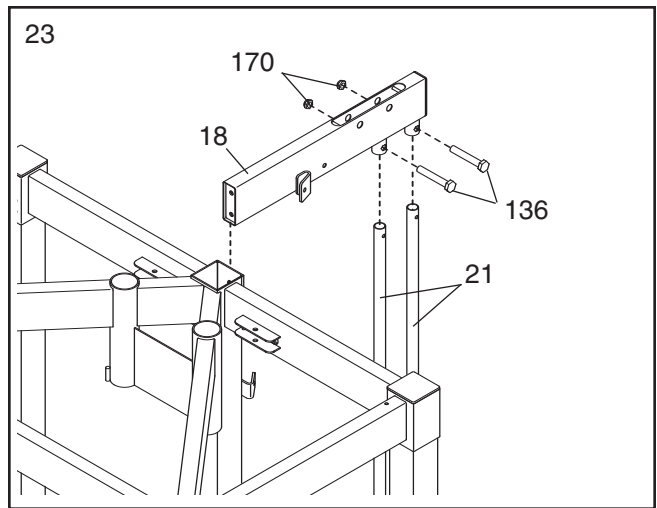

24. Attach the Weight Carriage Frame (18) to the Center Upright (13) and the Top Frame (17) with two M10 x 25mm Screws (128). Then, press a 75mm Square Inner Cap (95) into the Top Frame.

**See step 21. Tighten the M10 Nylon Locknuts (153). See step 23. Tighten the M8 Nylon Locknuts (170).**

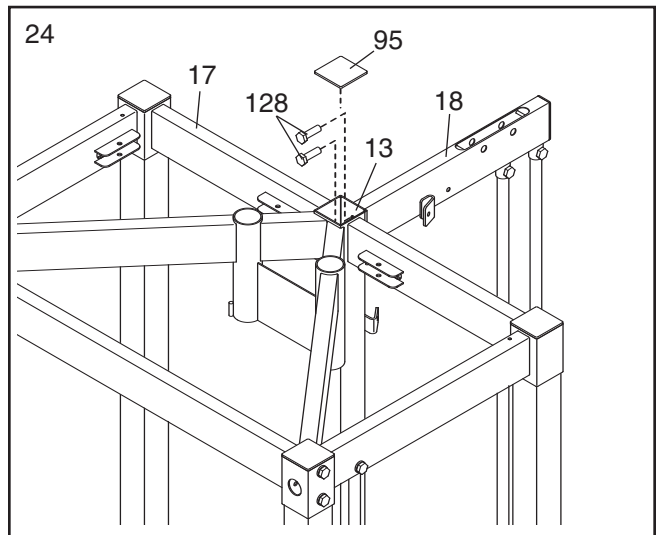

25. Grease the top of the Right Adjustment Bracket (24), and insert it into the Top Frame (17). **See the inset drawing.** Orient two Bracket Retainers (73) so that the teeth bend **upward**, and press them onto the Right Adjustment Bracket.

Attach the Right Adjustment Bracket (24) to the Top Frame (17) with an M10 x 30mm Screw (134), an M10 Lock Washer (86), an M10 Large Washer (171), and a Bushing Cap (88). **Do not overtighten the Screw; the Right Adjustment Bracket must pivot easily.**

**Attach the Left Adjustment Bracket (25) in the same way.**

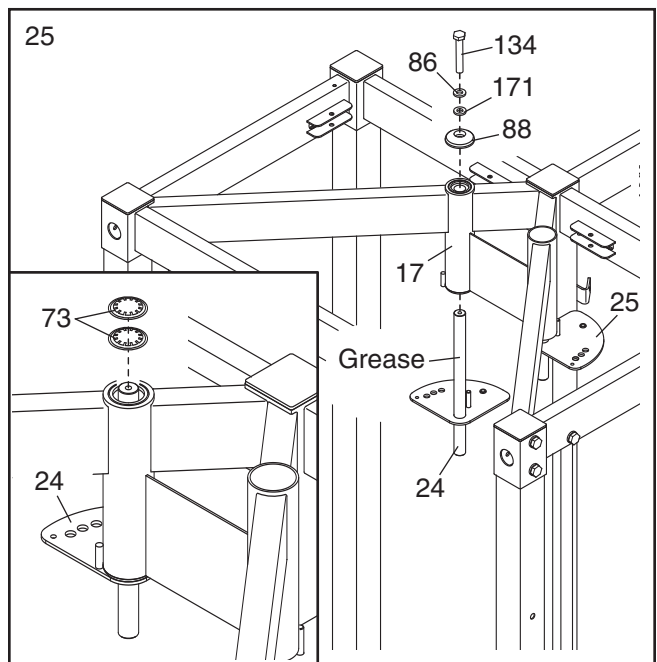



26. Grease the bottom of the Right Adjustment Bracket (24), and slide the Right Arm (23) onto the Right Adjustment Bracket. **See the inset drawing.** Orient two Bracket Retainers (73) so that the teeth bend **downward**, and press them onto the Right Adjustment Bracket.

Attach the Right Arm (23) to Right Adjustment Bracket (24) with an M10 x 30mm Screw (134), an M10 Lock Washer (86), an M10 Large Washer (171), and a Bushing Cap (88). **Do not overtighten the Screw; the Right Arm must pivot easily.**

Pull the Arm Knob (85), and engage it into a hole in the Right Adjustment Bracket (24). Then, attach an M6 x 15mm Bolt (144) to the Right Adjustment Bracket with an Adjustment Bracket Bushing (157) and an M6 Nylon Locknut (156).

**Attach the Left Arm (22) to the Left Adjustment Bracket (25) in the same way.**

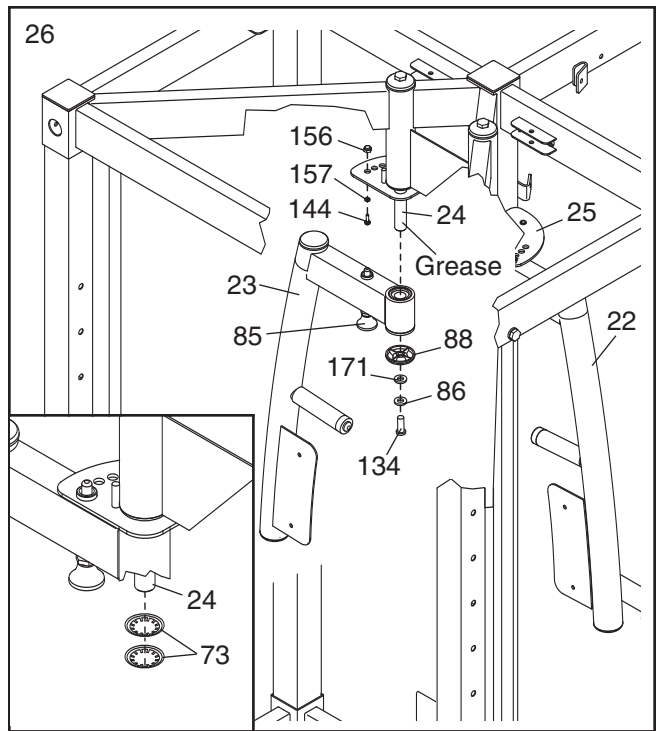

27. Identify the Right Arm Pad (89), which is labeled with an "R." Attach the Right Arm Pad to the Right Arm (23) with two M6 x 16mm Screws (141).

**Attach the Left Arm Pad (90) to the Left Arm (22) in the same way.**

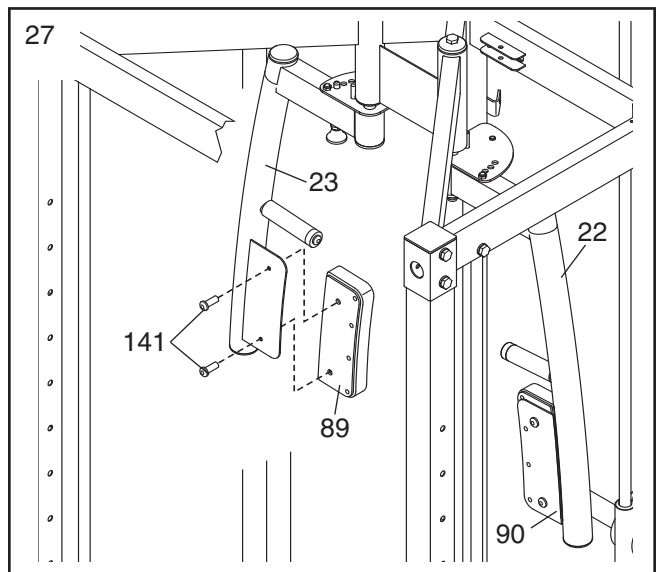

28. Attach the Butterfly Backrest (69) to the Center Upright (13) with two M6 x 90mm Screws (126) and two M6 Washers (149).

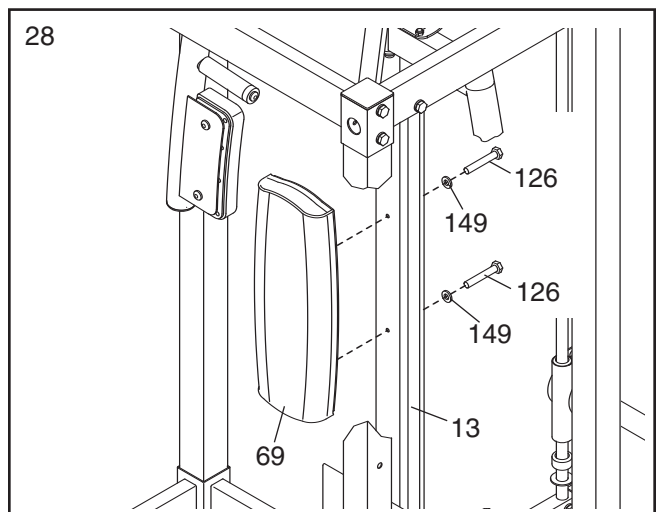

29. Orient the Locking Bar (114) as shown. Hold the Locking Bar between the left Barbell Carriage (104) and the right Barbell Carriage (not shown). Insert the Barbell (113) into the left Barbell Carriage, the Locking Bar, and the right Barbell Carriage. **Center the Barbell in the Barbell Carriages.** Then, engage the Locking Bar into slots in the Front Uprights (11).

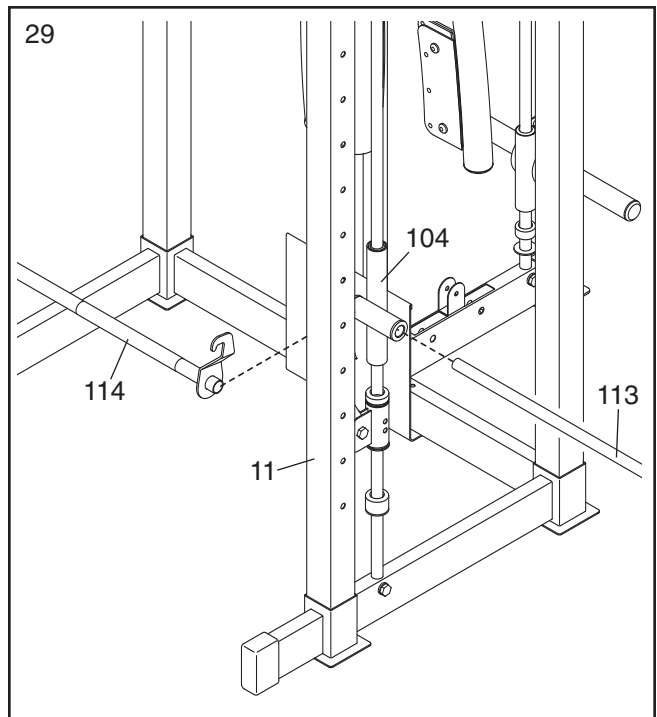

30. Attach a Barbell Adapter (102) to the Barbell (113) with an M10 x 25mm Screw (128) and a Large Washer (135). Then, press a 48mm x 3mm Round Inner Cap (103) into the Barbell Adapter.

**Attach the other Barbell Adapter (not shown) in the same way.**

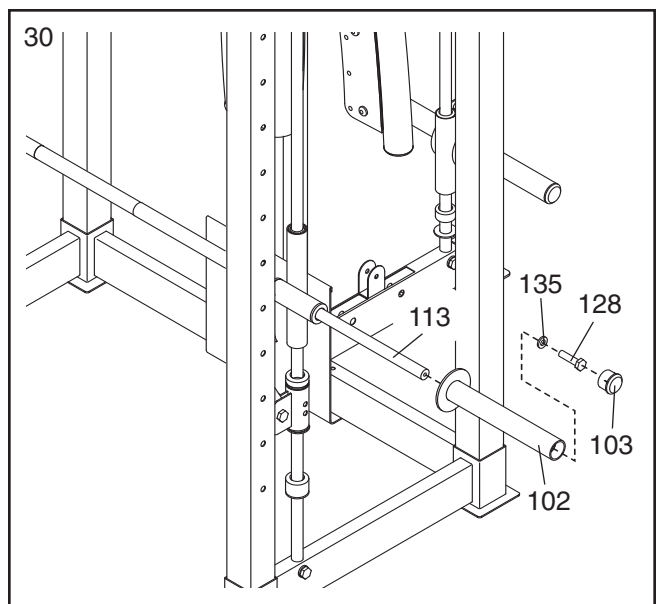

31. Insert a Phillips screwdriver into the indicated hole in a Swivel Bracket (31). Use the Phillips screwdriver to tighten the Trunnion (70) and the Swivel Bracket into the Top Frame (17).

**Attach the other Swivel Bracket (not shown) in the same way.**

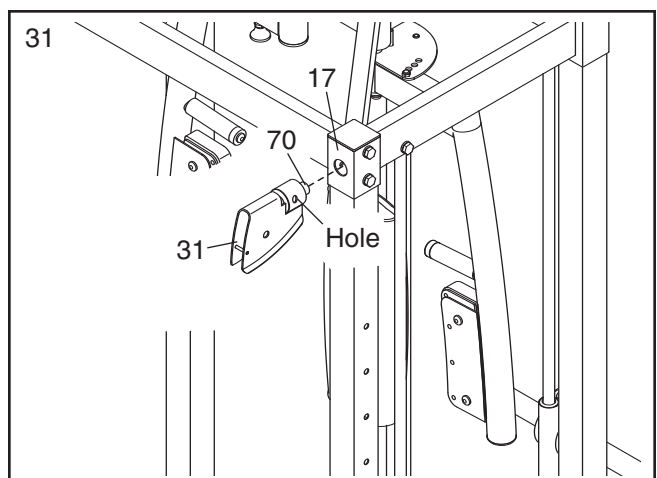

32. Tighten three Weight Storage Tubes (67) onto a Rear Upright (12).

**Attach the remaining three Weight Storage Tubes (not shown) onto the other Rear Upright (12) in the same way.**

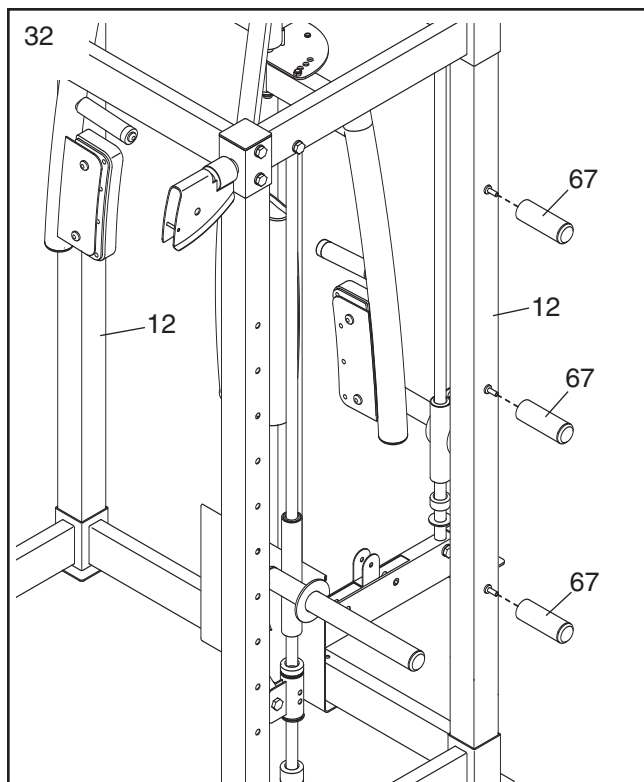

33. Attach an Upright Pin/Tether (28) to a Weight Rest (26) with an M4 x 16mm Self-tapping Screw (147). Hold the Weight Rest against one of the Front Uprights (11), and fully insert the Upright Pin into the Weight Rest and into one of the holes in the Front Upright. **Do not overtighten the Screw; the Tether must rotate easily.**

Attach an Upright Pin/Tether (28) to a Weight Spotter (29) with an M4 x 16mm Self-tapping Screw (147). Hold the Weight Spotter against the Front Upright (11), and fully insert the Upright Pin into the Weight Spotter and into one of the holes in the Front Upright.

**Attach the other Weight Rest (not shown) and the other Weight Spotter (not shown) to the other Front Upright (not shown) in the same way.**

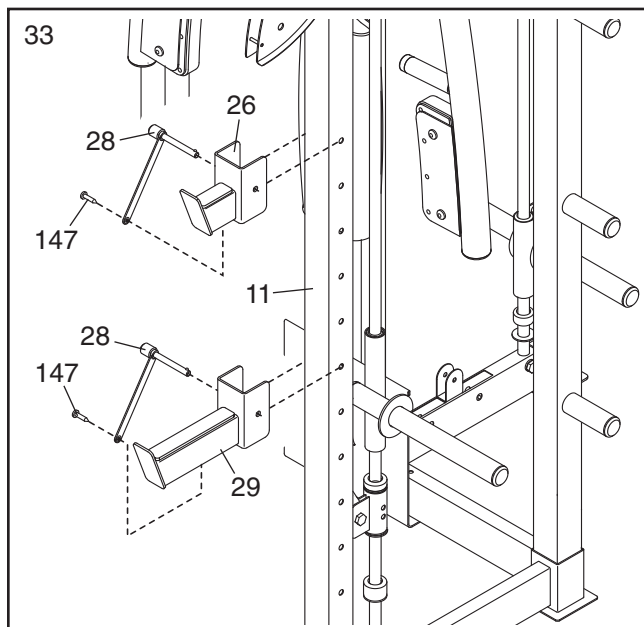

34. See the **CABLE DIAGRAM** on page 34 to identify the cables as you assemble them.

**Identify the Arm Cable (145).** Grease an M8 x 22mm Shoulder Bolt (143). Attach the Cable to the Left Adjustment Bracket (25) with the Shoulder Bolt and an M8 Nylon Locknut (170). **Make sure that the flat edge of the cable is against the Adjustment Bracket. Do not over-tighten the Shoulder Bolt; the Cable must pivot easily.**

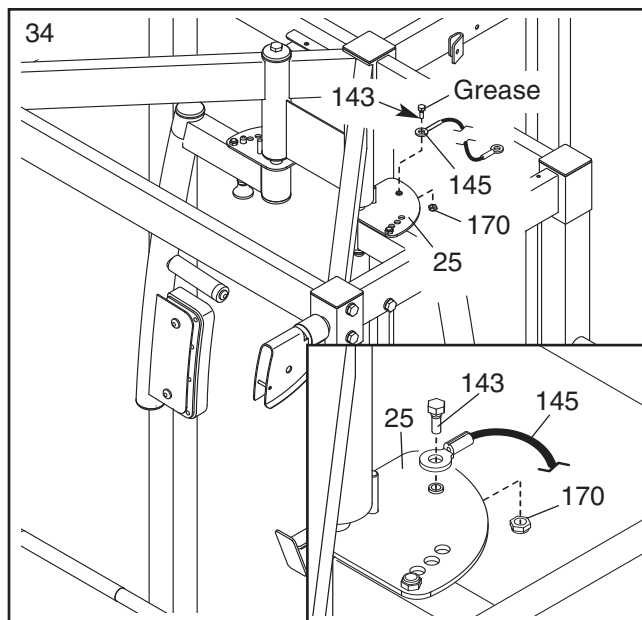

35. **Identify the two “V”-pulleys (75), which are wider than the other pulleys.** Wrap the Arm Cable (145) over a “V”-pulley. Attach the “V”-pulley, a Large Cable Trap (77), and two Full Pulley Guards (76) to the indicated bracket on the Center Upright (13) with an M10 x 60mm Bolt (133) and an M10 Nylon Locknut (153). **Make sure that the Cable Trap is oriented to hold the Cable in the groove of the “V”-pulley.**

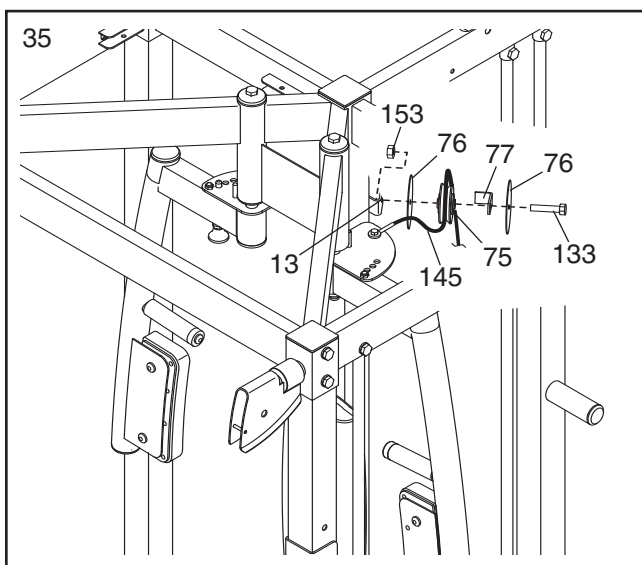

36. Wrap the Arm Cable (145) under a Small Pulley (74). Attach the Small Pulley and two Half Pulley Guards (91) to the Double “U”-bracket (98) with an M10 x 45mm Bolt (140) and an M10 Nylon Locknut (153). **Make sure that the Half Pulley Guards are oriented as shown.**

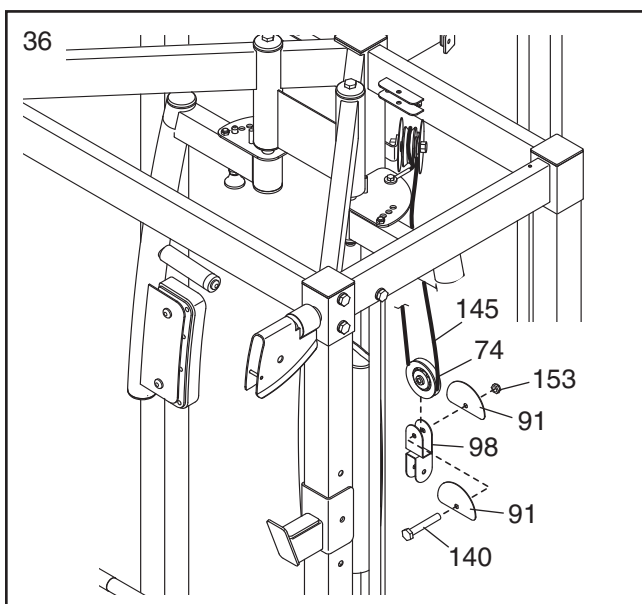

37. Wrap the Arm Cable (145) over a “V”-pulley (75). Attach the “V”-pulley, a Large Cable Trap (77), and two Full Pulley Guards (76) to the other side of the bracket on the Center Upright (13) with an M10 x 60mm Bolt (133) and an M10 Nylon Locknut (153). **Make sure that the Cable Trap is oriented to hold the Cable in the groove of the “V”-pulley.**

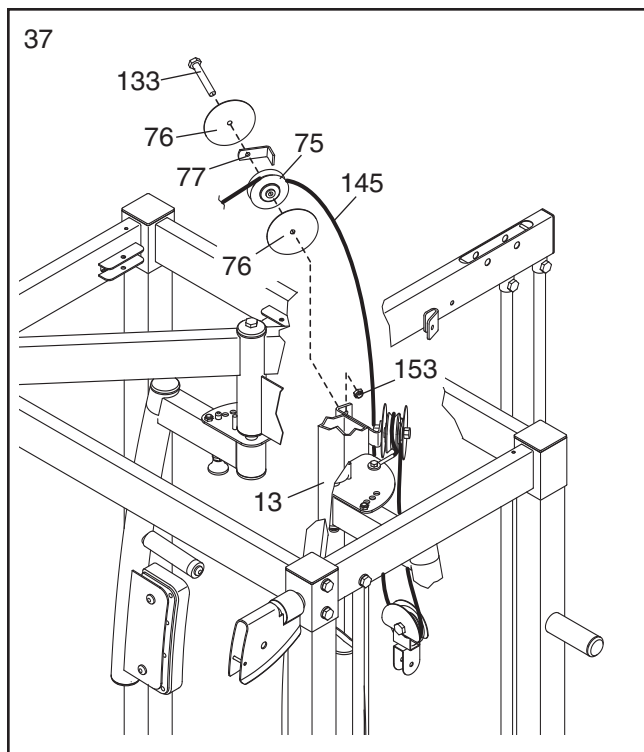

38. Grease an M8 x 22mm Shoulder Bolt (143). Attach the Arm Cable (145) to the Right Adjustment Bracket (24) with the Shoulder Bolt and an M8 Nylon Locknut (170). **See the inset drawing. Make sure that the flat edge of the cable is against the Adjustment Bracket. Do not overtighten the Shoulder Bolt; the Cable must pivot easily.**

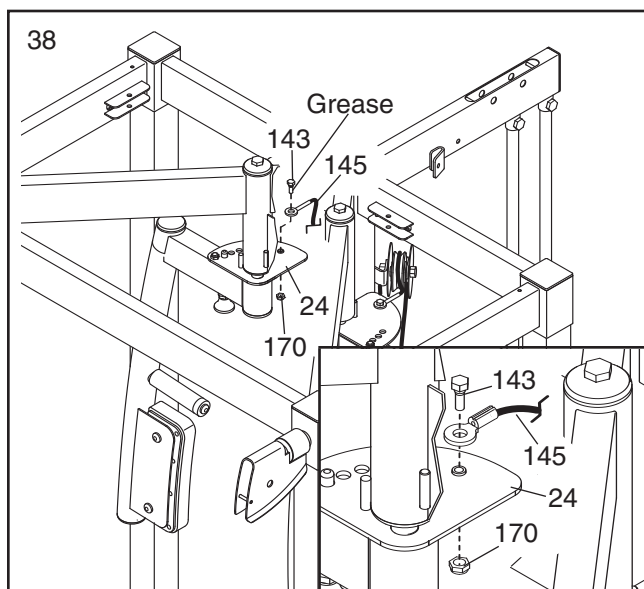

39. **Identify the High Cable (81).** Feed the Cable under the indicated rod into the right Swivel Bracket (31). Continue feeding the Cable into the Top Frame (17), and then pull the end of the Cable out of the indicated slot in the Top Frame.

Wrap the High Cable (81) over a Large Pulley (165). Attach the Large Pulley to the Swivel Bracket (31) with an M10 x 55mm Bolt (127), two M10 Washers (148), two M10 x 6.5mm Spacers (151), and an M10 Nylon Locknut (153).

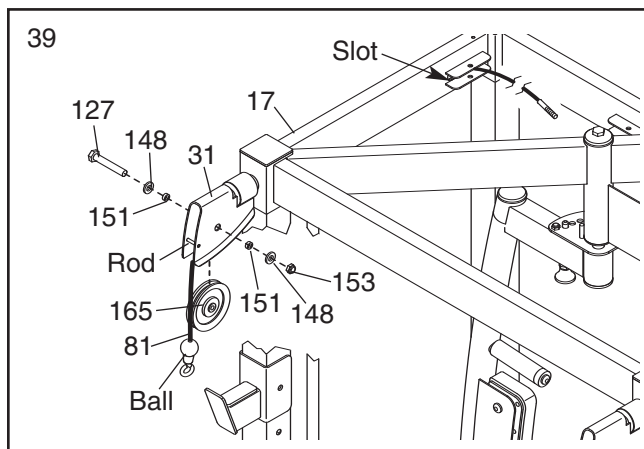

40. Wrap the High Cable (81) around a Small Pulley (74). Attach the Small Pulley to the Top Frame (17) with an M10 x 45mm Bolt (140) and an M10 Nylon Locknut (153).

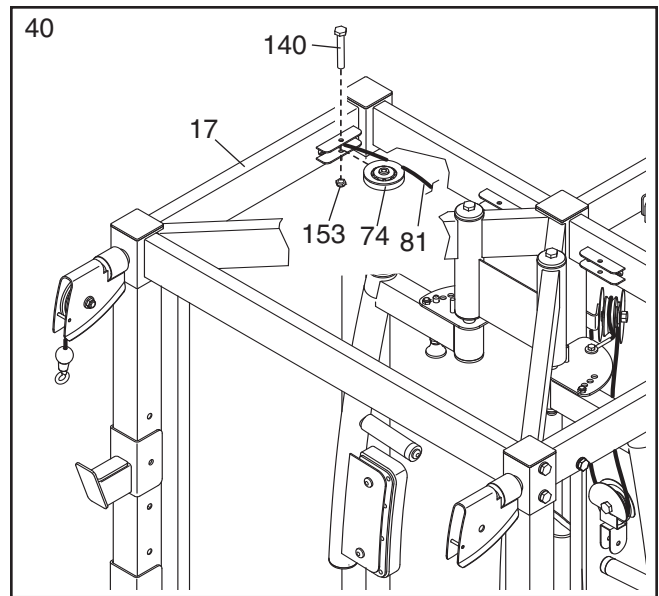

41. Feed the High Cable (81) through the indicated slot in the Top Frame (17). Wrap the Cable around a Small Pulley (74). Attach the Small Pulley to the Top Frame with an M10 x 45mm Bolt (140) and an M10 Nylon Locknut (153).

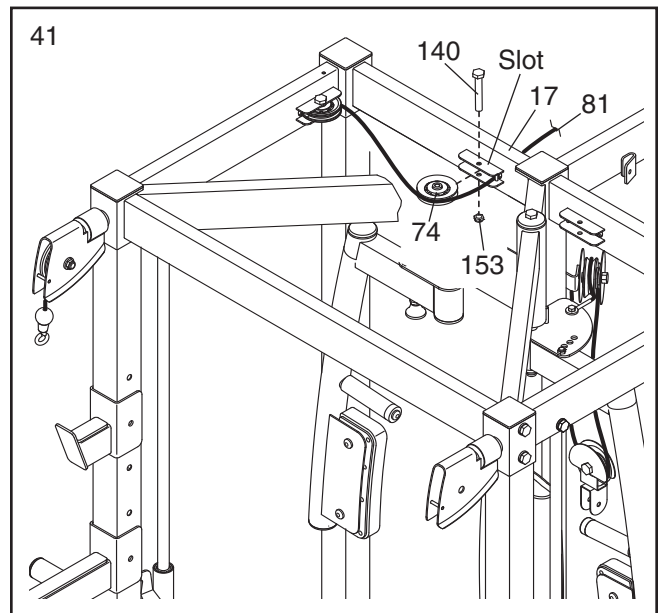

42. Wrap the High Cable (81) over a Small Pulley (74). Attach the Small Pulley, a Small Cable Trap (93), and two Half Pulley Guards (91) to the indicated bracket on the Weight Carriage Frame (18) with an M10 x 48mm Bolt (125) and an M10 Nylon Locknut (153). **Make sure that the Cable Trap and the Half Pulley Guards are oriented as shown.**

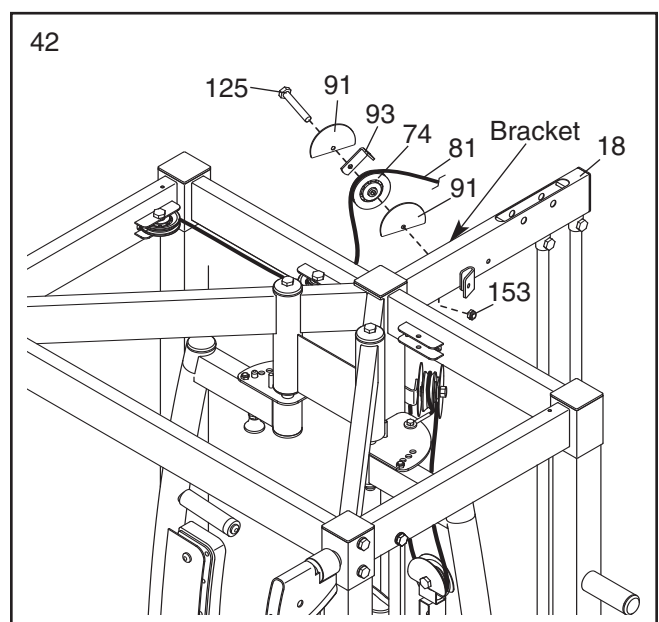

43. Wrap the High Cable (81) under a Small Pulley (74). Attach the Cable, a Small Cable Trap (93), and two Half Pulley Guards (91) to the second hole from the top of the "U"-bracket (158) with an M10 x 48mm Bolt (125) and an M10 Nylon Locknut (153). **Make sure that the Cable Trap and the Half Pulley Guards are oriented as shown.**

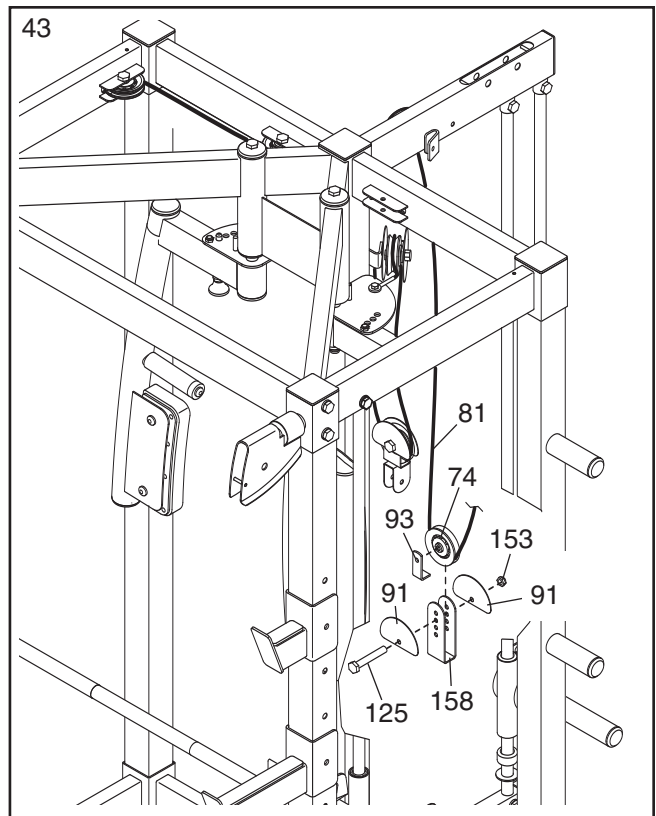

44. Wrap the High Cable (81) over a Small Pulley (74). Attach the Small Pulley, a Small Cable Trap (93), and two Half Pulley Guards (91) to the indicated bracket on the Weight Carriage Frame (18) with an M10 x 48mm Bolt (125) and an M10 Nylon Locknut (153). **Make sure that the Cable Trap and the Half Pulley Guards are oriented as shown.**

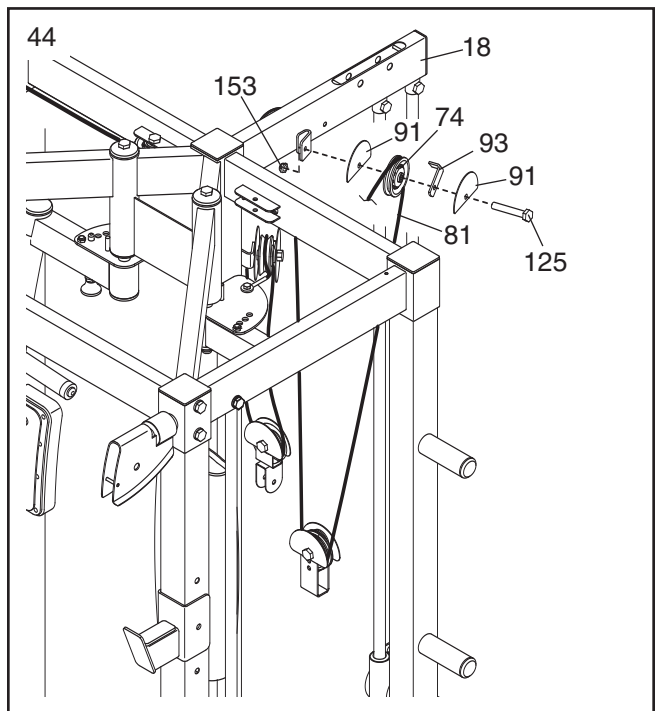



45. Feed the High Cable (81) through the indicated slot in the Top Frame (17). Wrap the Cable around a Small Pulley (74). Attach the Small Pulley to the Top Frame with an M10 x 45mm Bolt (140) and an M10 Nylon Locknut (153).

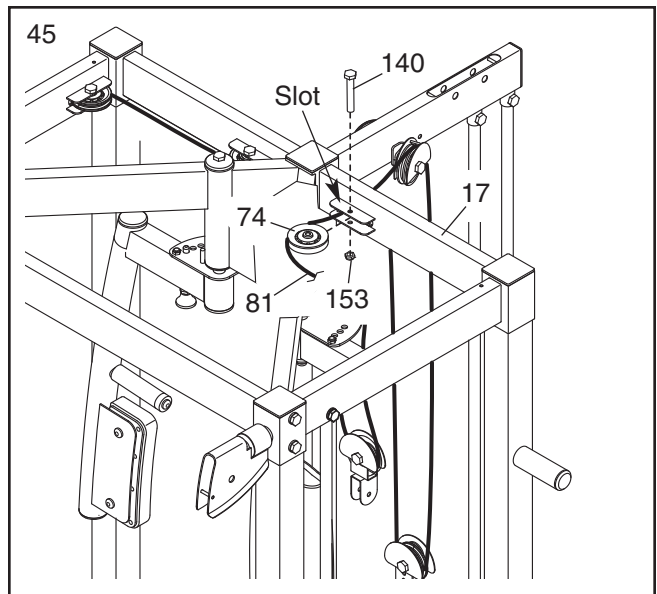

46. Feed the High Cable (81) through the Top Frame (17).

**See the inset drawing.** Insert the Cabling Rod (175) into the left Swivel Bracket (31) and the Top Frame (17). Attach the Cabling Rod to the High Cable (81). Then, pull the Cabling Rod and the Cable out of the Swivel Bracket. **Make sure that the Cable is under the indicated rod.**

Wrap the High Cable (81) around a Small Pulley (74). Attach the Small Pulley to the Top Frame with an M10 x 45mm Bolt (140) and an M10 Nylon Locknut (153).

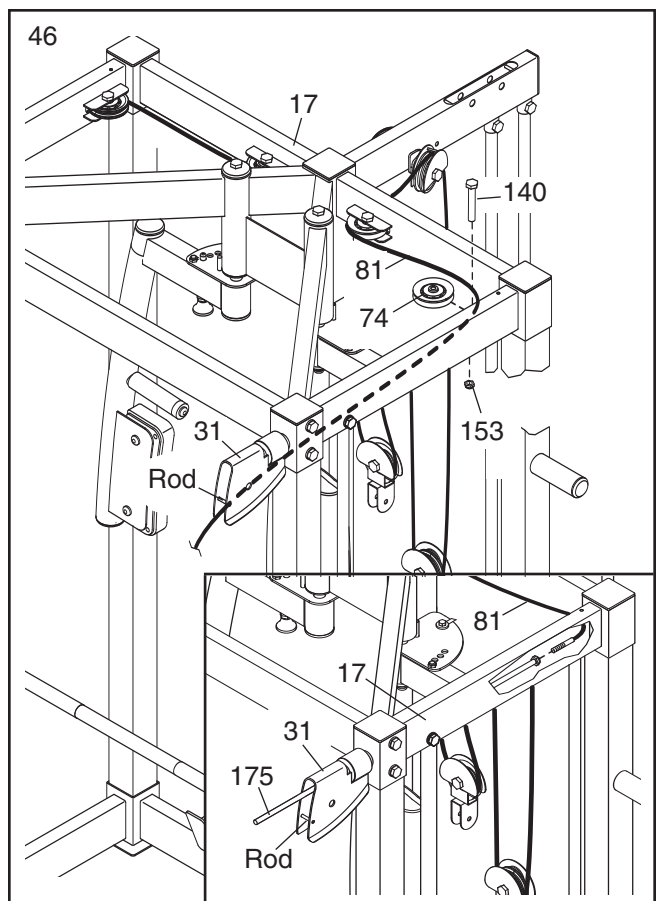



47. Wrap the High Cable (81) over a Large Pulley (165). Attach the Large Pulley to the Swivel Bracket (31) with an M10 x 55mm Bolt (127), two M10 Washers (148), two M10 x 6.5mm Spacers (151), and an M10 Nylon Locknut (153).

Tighten the Cable Eyelet (174) as far as possible onto the end of the High Cable (81). Then, tighten the M8 Jam Nut (177) against the Cable Eyelet.

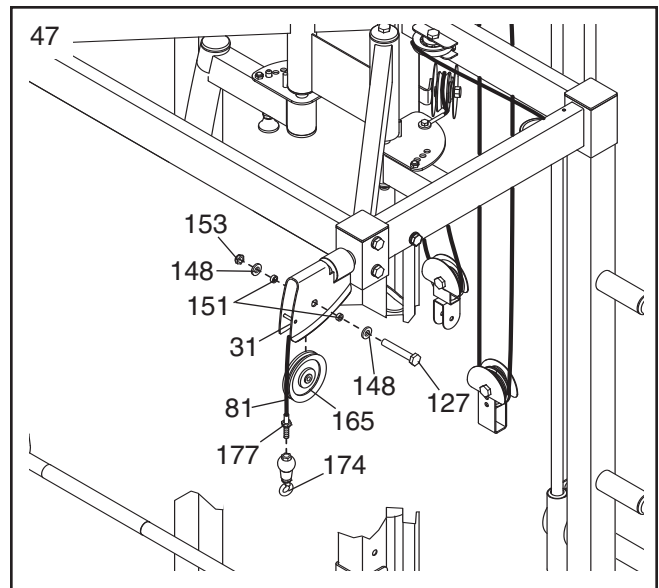

48. **Identify the Rear Cable (94).** Press the Weight Carriage Block (100) into the Weight Carriage (19). Insert one end of the Rear Cable into the center of the Weight Carriage Block. Attach the Cable and the Weight Carriage Block to the Weight Carriage with an M10 x 65mm Bolt (137), two M10 Washers (148), two M10 x 20mm Spacers (150), and an M10 Nylon Locknut (153).

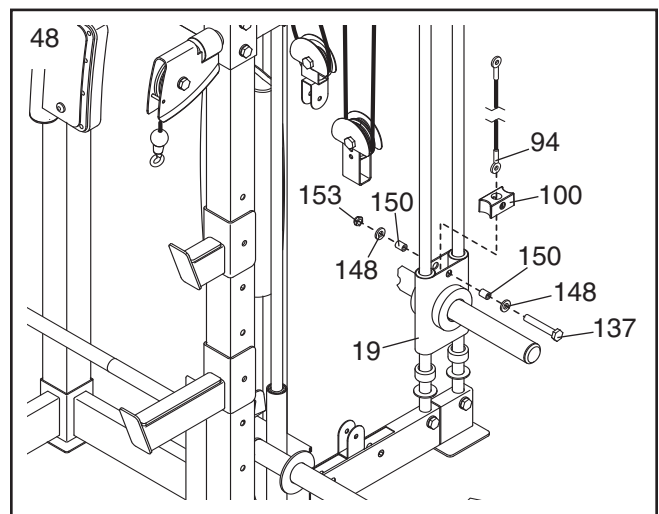

49. Route the Rear Cable (94) through the Weight Carriage Frame (18) as shown. Insert a Small Pulley (74) into the slot in the Weight Carriage Frame. Then, insert another Small Pulley (74). Attach each Small Pulley with an M10 x 55mm Bolt (127), two M10 Washers (148), two M10 x 6.5mm Spacers (151), and an M10 Nylon Locknut (153).

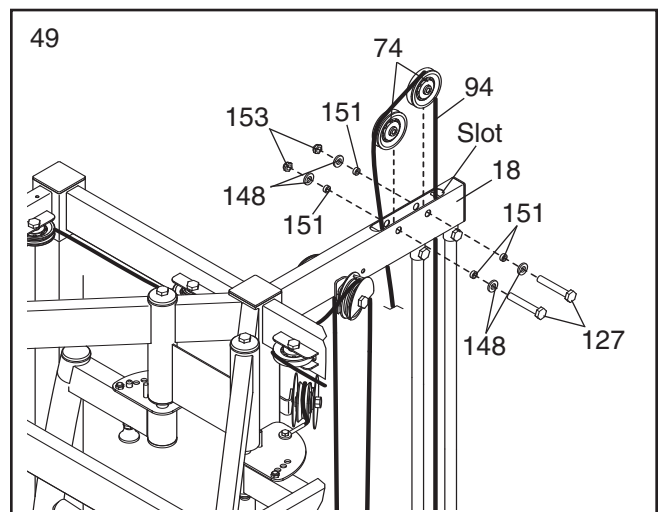

50. Wrap the Rear Cable (94) under a Small Pulley (74). Attach the Small Pulley, a Small Cable Trap (93), and two Half Pulley Guards (91) at the second hole from either end of the two Pulley Plates (92) with an M10 x 48mm Bolt (125) and an M10 Nylon Locknut (153). **Make sure that the Cable Trap and the Half Pulley Guards are oriented as shown.**

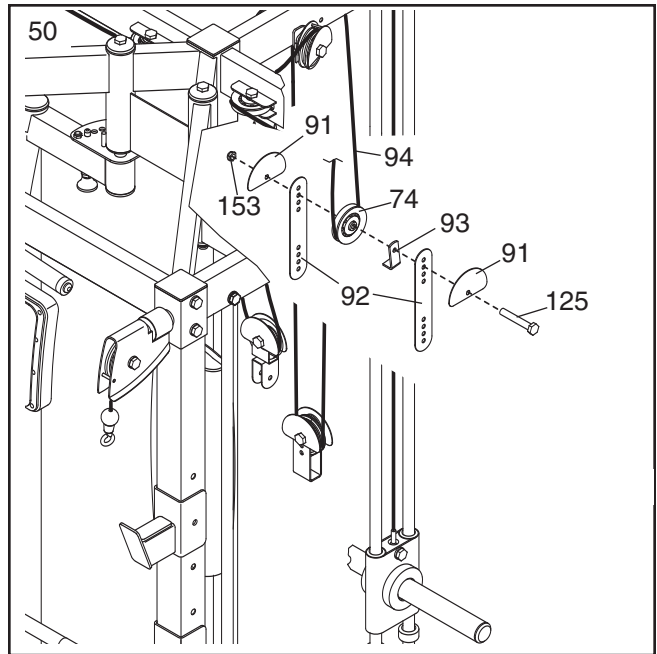

51. Attach the Rear Cable (94) inside the Weight Carriage Frame (18) with an M10 x 55mm Bolt (127), two M10 Washers (148), and an M10 Nylon Locknut (153).

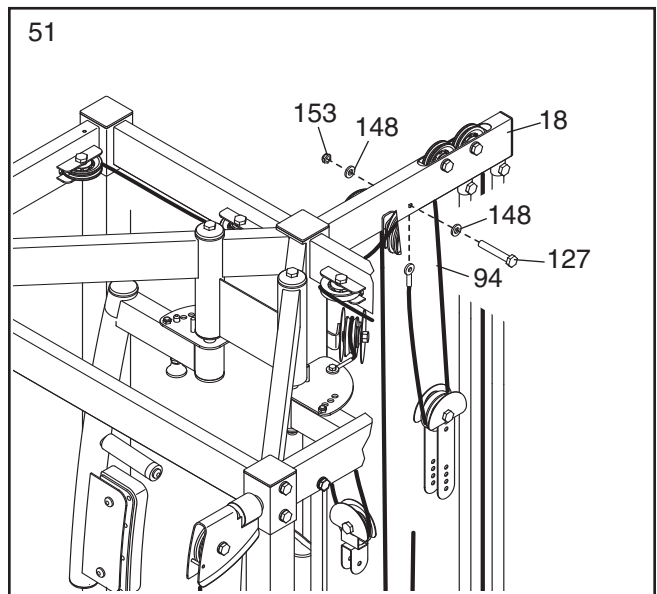

52. **Identify the Low Cable (80).** Route the threaded end of the Cable through the Foot Plate (15) and the Center Upright (13).

Wrap the Low Cable (80) under a Large Pulley (165). Attach the Large Pulley inside the Center Upright (13) with an M10 x 93mm Bolt (129), two M10 Washers (148), two M10 x 25mm Spacers (169), and an M10 Nylon Locknut (153).

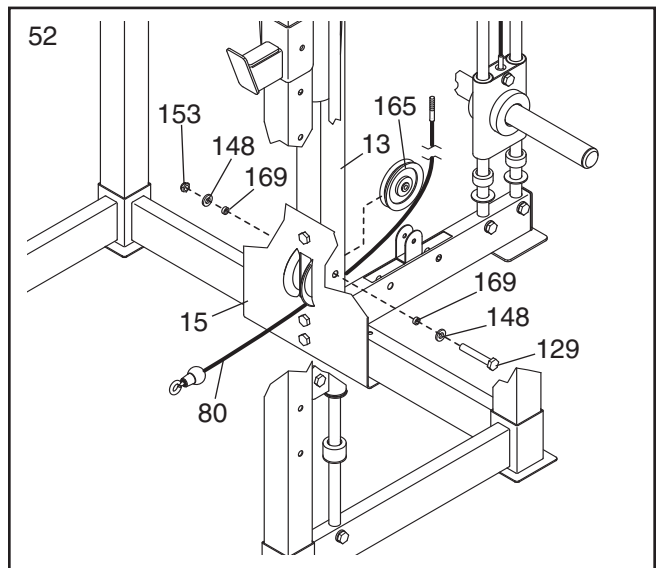

53. Wrap the Low Cable (80) over a Small Pulley (74). Attach the Small Pulley and two Half Pulley Guards (91) to the Double “U”-bracket (98) with an M10 x 45mm Bolt (140) and an M10 Nylon Locknut (153). **Make sure that the Half Pulley Guards are oriented as shown.**

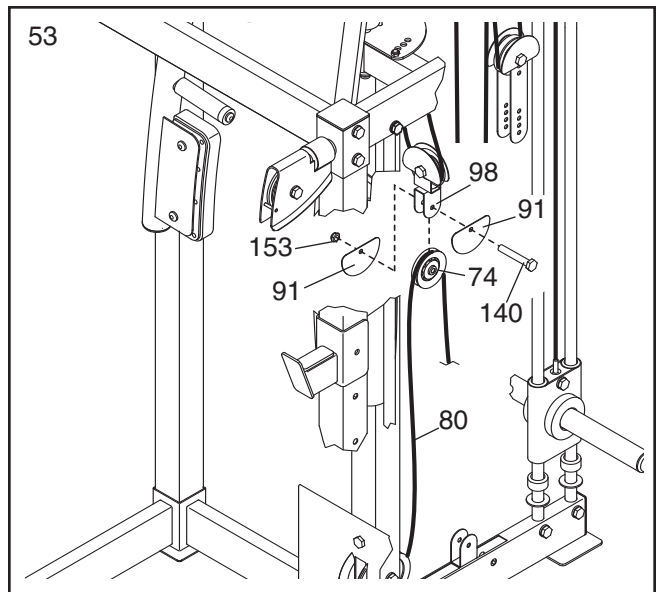

54. Route the Low Cable (80) through the Weight Carriage Base (20) as shown. Attach two Small Pulleys (74) inside the Weight Carriage Base with two M10 x 55mm Bolts (127), four M10 Washers (148), four M10 x 6.5mm Spacers (151), and two M10 Nylon Locknuts (153).

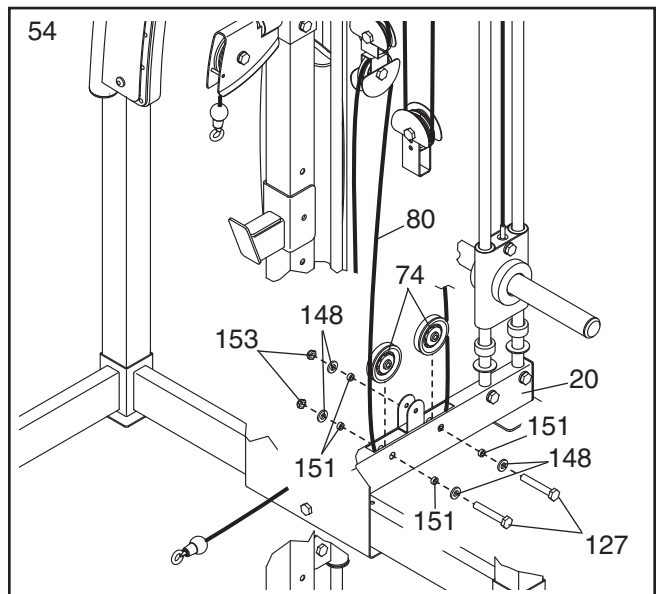

55. Wrap the Low Cable (80) over a Small Pulley (74). Attach the Small Pulley, a Small Cable Trap (93), and two Half Pulley Guards (91) at the second hole from the bottom of the two Pulley Plates (92) with an M10 x 48mm Bolt (125) and an M10 Nylon Locknut (153). **Make sure that the Cable Trap and the Half Pulley Guards are oriented as shown.**

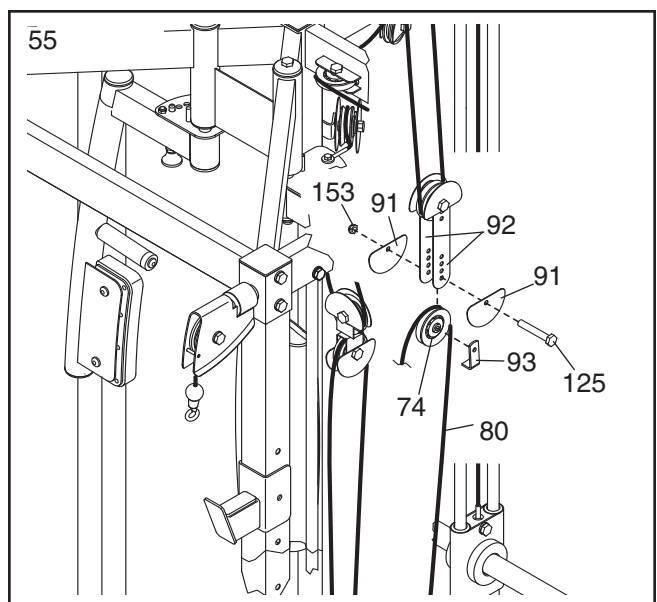

56. Wrap the Low Cable (80) under a Small Pulley (74). Attach the Small Pulley and two Half Pulley Guards (91) to the Weight Carriage Base (20) with an M10 x 45mm Bolt (140) and an M10 Nylon Locknut (153). **Make sure that the Half Pulley Guards are oriented as shown.**

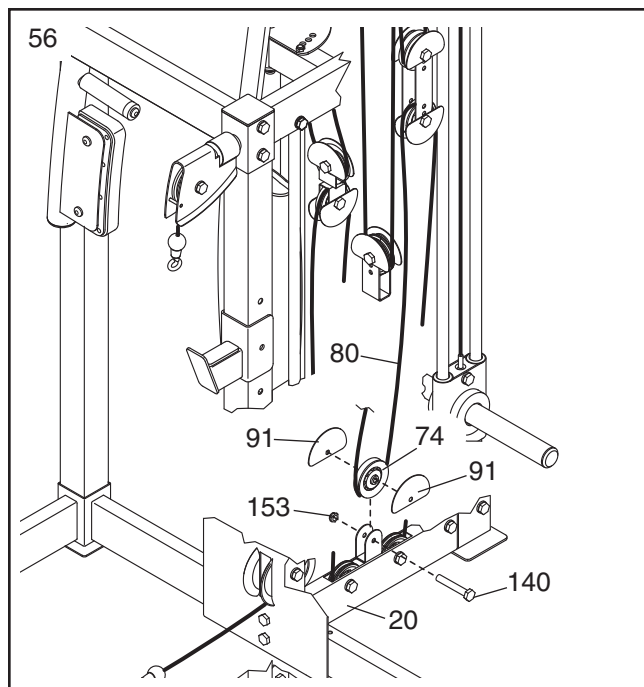

57. Attach the Low Cable (80) to the "U"-bracket (158) with an M8 Nylon Locknut (170) and an M8 Washer (164) (see the inset drawing). **Tighten the Nylon Locknut exactly two full turns onto the Cable.**

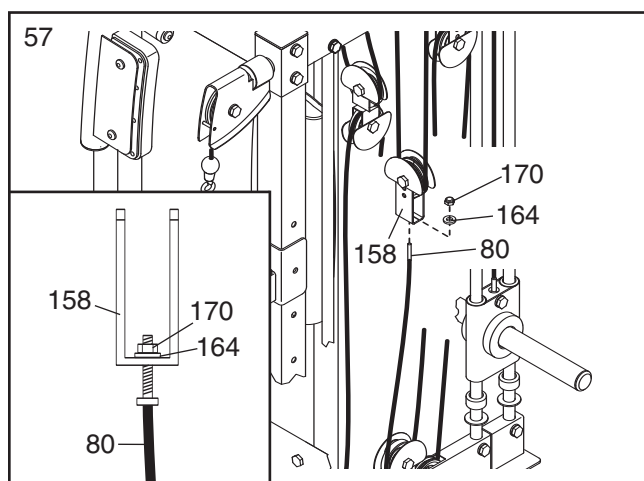

58. Make sure that all parts have been properly tightened. The use of the remaining parts will be explained in ADJUSTMENT, beginning on the following page.

Before using the weight bench, pull each cable a few times to make sure that the cables move smoothly over the pulleys. If one of the cables does not move smoothly, find and correct the problem. **IMPORTANT: If the cables are not properly installed, they may be damaged when heavy weight is used. See the CABLE DIAGRAM on page 34 for proper cable routing. If there is any slack in the cables, you will need to remove it by tightening the cables. See MAINTENANCE on page 33.**

# ADJUSTMENT

This section explains how to adjust the weight bench. See the EXERCISE GUIDELINES on page 35 for important information about how to get the most benefit from your exercise program. Also, refer to the accompanying exercise guide to see the correct form for several exercises.

## ADJUSTING THE SEAT AND BACKREST

To adjust the position of the Seat (33) and the Backrest (32), first pull the Seat Knob (56). Next, slide the Seat Carriage (6) along the Bench Frame (1) to the desired position and release the Seat Knob.

**Move the Seat Carriage back and forth slightly to make sure that the Seat Knob is engaged in one of the holes in the Bench Frame.**

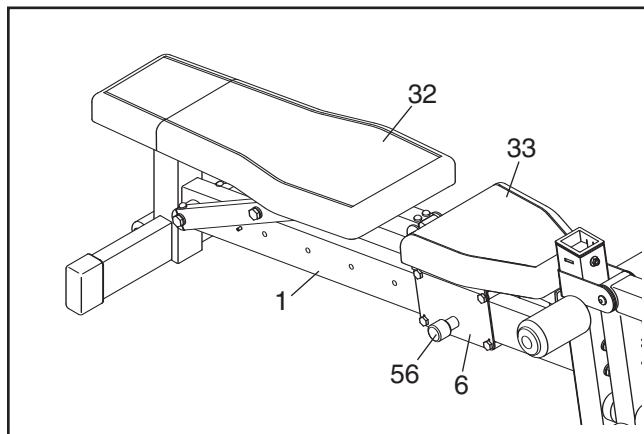

## ATTACHING THE CURL PAD

To use the Curl Pad (34), insert the Curl Post (10) into the Front Leg (3) and secure the Curl Post with the Post Knob (44). **Firmly tighten the Post Knob.**

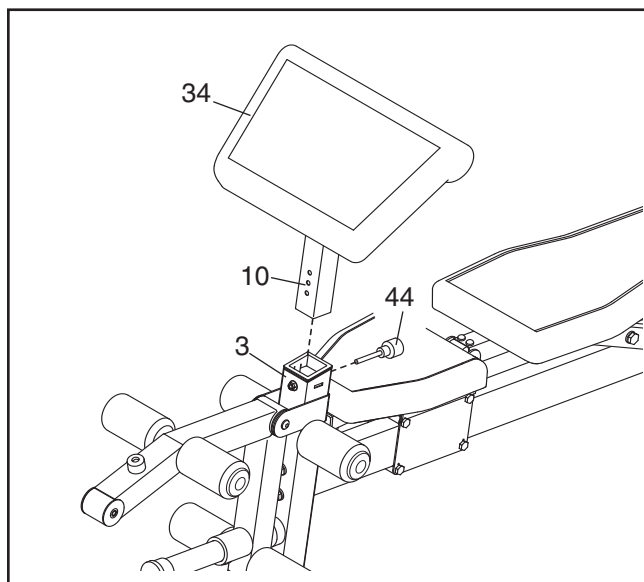

## ATTACHING THE CURL BAR

Attach the Curl Bar Frame (5) to the Leg Lever (4) with the Curl Bar Pin (36).

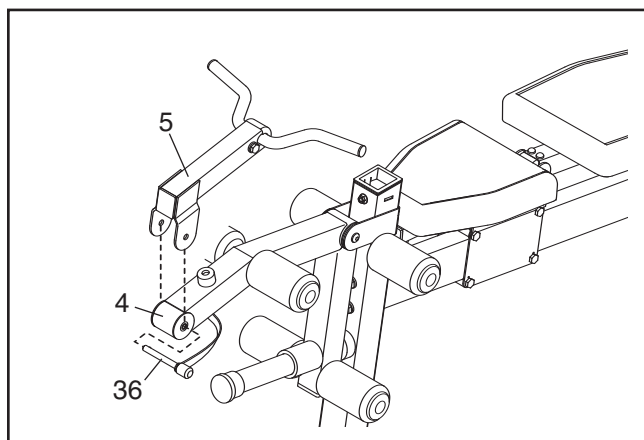

## USING THE LEG LEVER

To use the Leg Lever (4), slide the desired weights (not included) onto the Leg Lever. Secure the weights with the Weight Clip (132). You can store unused weights on the weight storage tubes (not shown) on the rear uprights.

**⚠️ WARNING:** Do not put more than 150 lbs. (68 kg) on the Leg Lever (4). Always secure weights with a Weight Clip (132).

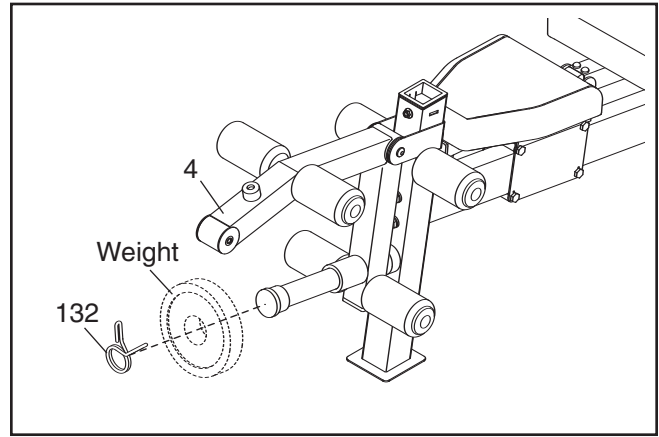

## USING THE WEIGHT RESTS AND THE WEIGHT SPOTTERS

Before using a separate barbell (not included), set the Weight Spotters (29) at the lowest point to which you want your barbell to move.

To do this, hold a Weight Spotter (29) and pull out the Upright Pin (28). Move the Weight Spotter to the desired height, and reengage the Upright Pin into the Weight Spotter and the Front Upright (11).

**Adjust the other Weight Spotter (not shown) and the two Weight Rests (26) in the same way.**

**⚠️ WARNING:** Always adjust both Weight Spotters (29) and both Weight Rests (26) to the same height.

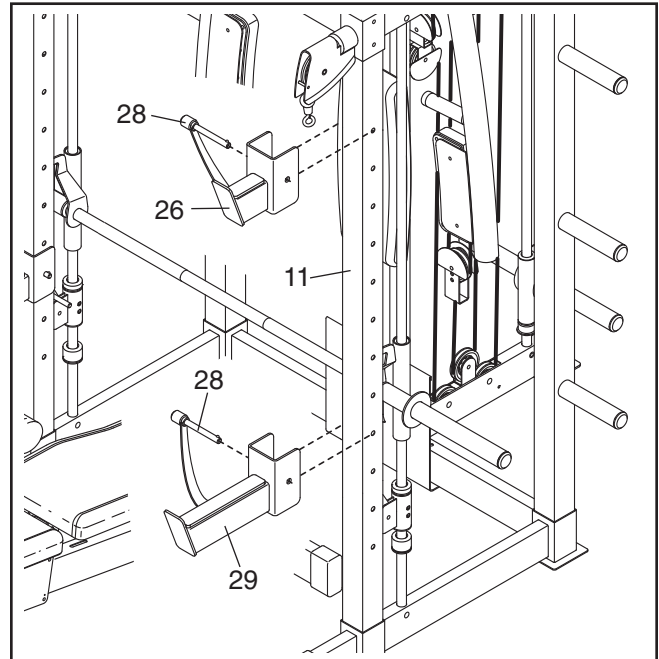

## MOVING THE BARBELL SPOTTERS

To move the left Barbell Spotter (109), grip the handle on the Left Spotter Hook (115) and pull the hook out of the slot in the Front Upright (11). Raise or lower the Barbell Spotter to a new position, and pivot the hook back into a slot in the Front Upright. **Note: Always start an exercise with the Barbell Spotters positioned at the lowest point to which you want the Barbell (113) to move during the exercise.**

**Adjust the right Barbell Spotter (not shown) in the same way.**

**⚠️ WARNING:** Always set both Barbell Spotters (109) at the same height.

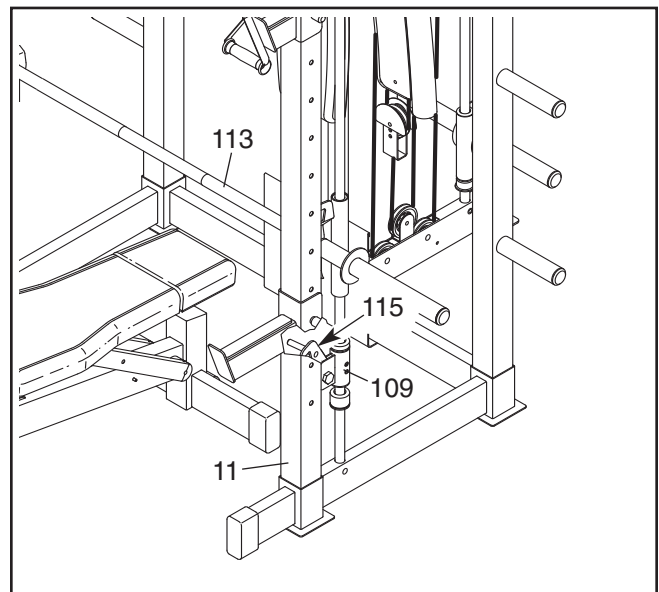



## USING THE LOCKING BAR

Grip the Locking Bar (114) with both hands. Turn the Locking Bar until the two hooks disengage the slots in the Front Uprights (11). Raise or lower the Locking Bar to a new position and turn it until the hooks engage slots in the Front Uprights.

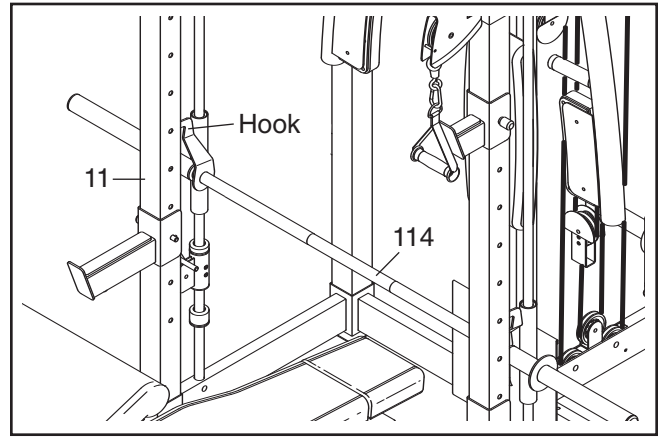

## ADJUSTING THE ARMS

To change the position of the Right Arm (23), pull the Arm Knob (85) out of the Right Adjustment Bracket (24). Then, rotate the Right Arm to the desired position, and reengage the Arm Knob into the Right Adjustment Bracket. **Change the position of the Left Arm (22) in the same way.**

**WARNING:** Always adjust both the Arms (23, 22) to the same position.

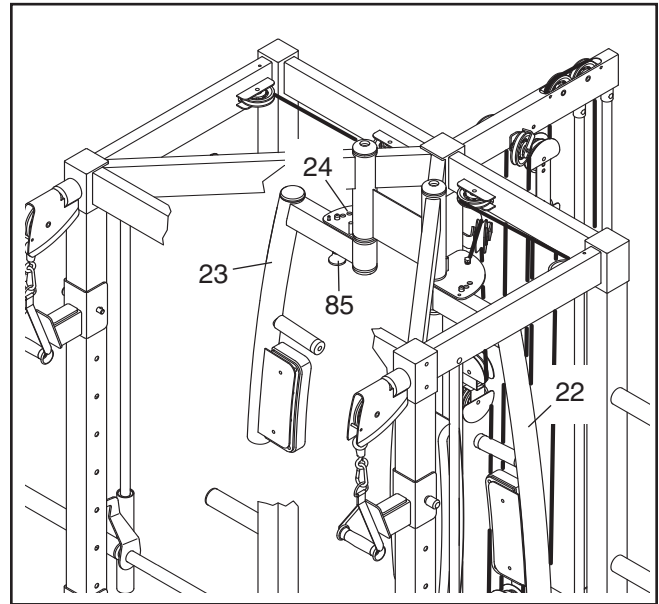

## ADDING WEIGHTS TO THE BARBELL OR THE WEIGHT CARRIAGE

To use the Barbell (113) or the Weight Carriage (19), slide the desired amount of weight (not included) onto the Barbell Adapters (102) or the Weight Carriage Tubes (96). Secure the weights with the Weight Clips (132).

**WARNING:** Do not place more than 310 lbs. (140 kg) on the Barbell (113), or 150 lbs. (68 kg) on the Weight Carriage (19). Always place the same amount of weight on each side of the Barbell or the Weight Carriage. Always secure weights with the Weight Clips (132).

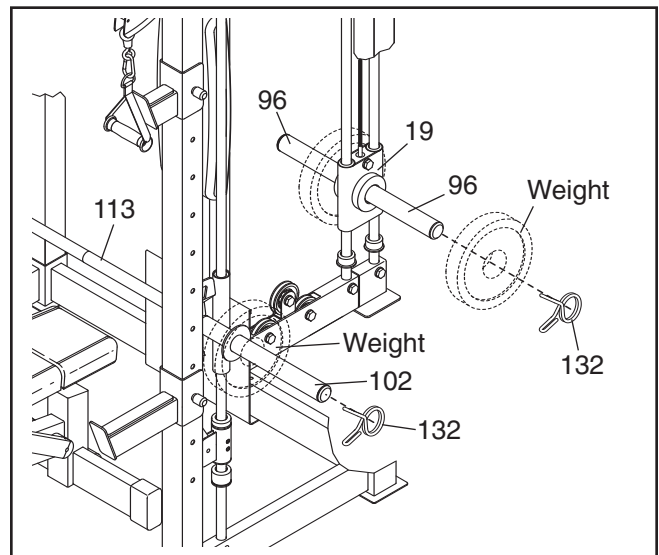

## ATTACHING THE ACCESSORIES TO THE HIGH PULLEY STATION

To use the high pulley station, first place the desired weights on the weight carriage (see **ADDING WEIGHTS TO THE BARBELL OR THE WEIGHT CARRIAGE** on page 31). Next, attach the Lat Bar (58) to the High Cable (81) with a Cable Clip (63). For some exercises, the Chain (176) should be attached between the Lat Bar and the Cable with two Cable Clips. **Adjust the length of the Chain between the Lat Bar and the Cable so that the Lat Bar is in the correct starting position for the exercise to be performed.**

**See the inset drawing.** The Pulley Handles (57) can be attached to the High Pulley (81) in the same way.

**⚠ WARNING:** Always disconnect the Lat Bar (58) when performing an exercise that does not require using the Lat Bar.

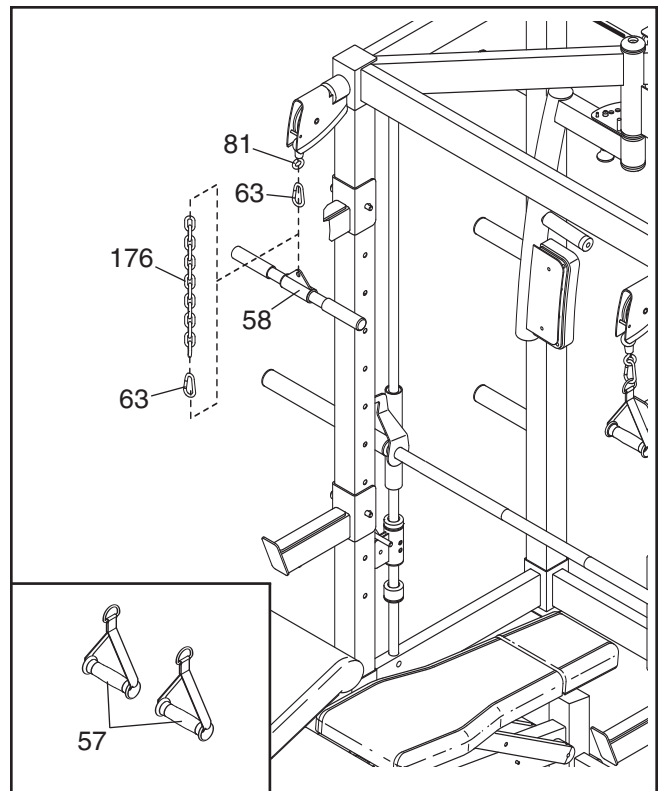

## ATTACHING THE ACCESSORIES TO THE LOW PULLEY STATION

To use the low pulley station, first place the desired weights on the weight carriage (see **ADDING WEIGHTS TO THE BARBELL OR THE WEIGHT CARRIAGE** on page 31). Next, attach the Lat Bar (58) to the Low Cable (80) with a Cable Clip (63). For some exercises, the Chain (176) should be attached between the Lat Bar and the Cable with two Cable Clips. **Adjust the length of the Chain between the Lat Bar and the Cable so that the Lat Bar is in the correct starting position for the exercise to be performed.**

**See the inset drawing.** The Ankle Strap (64), a Pulley Handle (57), and the Row Bar (65) can be attached to the Low Cable (80) in the same way.

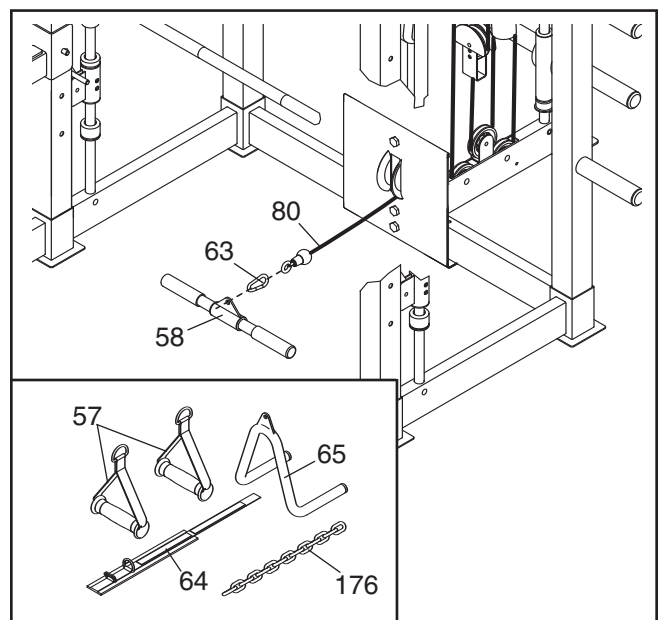



# MAINTENANCE

Make sure that all parts are properly tightened each time the weight bench is used. Replace any worn parts immediately. The weight bench can be cleaned with a damp cloth and a mild, non-abrasive detergent; **do not use solvents to clean the weight bench.**

## TIGHTENING THE CABLES

Woven cable, the type of cable used on the weight bench, can stretch slightly when it is first used. If there is slack in the cables before resistance is felt, the cables should be tightened. **See ADDING WEIGHTS TO THE WEIGHT CARRIAGE in the ADJUSTMENT section of this manual.** Add some weights to the weight carriage. Slack can be removed from the cables several ways:

Remove the M10 Nylon Locknut (153) and the M10 x 48mm Bolt (125) from the two Half Pulley Guards (91), the Small Cable Trap (93), and the Small Pulley (74) near the lower end of the two Pulley Plates (92). Reattach the Small Pulley, Cable Trap, and Half Pulley Guards to a hole closer to the center of the Pulley Plates. **Make sure that the Cable Trap is in the proper position and that the Cable and Pulley move smoothly.**

If necessary, adjust the position of the Pulley (74) near the upper end of the Pulley Plates (92) in the same way.

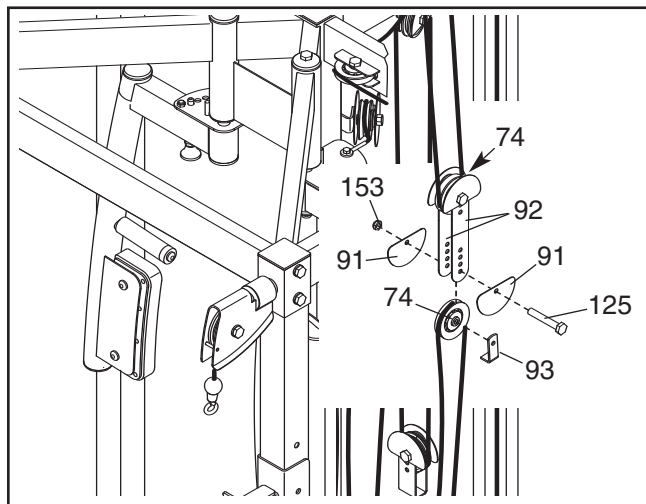

**See the inset drawing.** Tighten the M8 Nylon Locknut (170) that connects the end of the Low Cable (80) to the “U”-bracket (158).

Remove the M10 Nylon Locknut (153) and the M10 x 48mm Bolt (125) from the two Half Pulley Guards (91), the Small Cable Trap (93), and the Small Pulley (74) attached to the “U”-bracket (158). Reattach the Small Pulley, Cable Trap, and Half Pulley Guards to a lower hole in the “U”-bracket. **Make sure that the Cable Trap is in the proper position and that the Cable and Pulley move smoothly.**

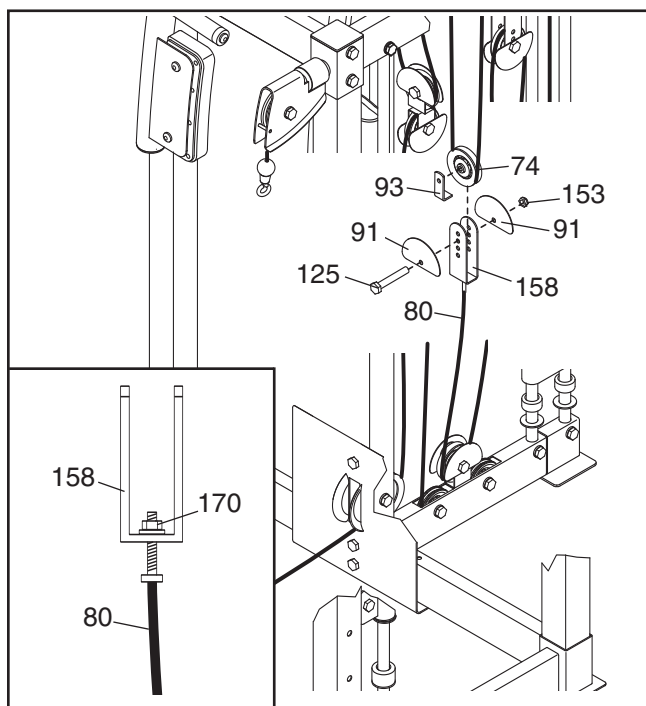

**Do not overtighten the cables. If a cable tends to slip off the pulleys often, it may have become twisted. Remove the cable and re-install it.** If a cable needs to be replaced, see ORDERING REPLACEMENT PARTS on the back cover of this manual.

# CABLE DIAGRAM

The diagram below shows the proper routing of the cables. The numbers in each drawing show the proper routing for that cable. Use the diagram to make sure that the cables, cable traps, and pulley guards are assembled correctly. If the cables, cable traps, and pulley guards are not assembled correctly, the weight bench will not function properly and damage may occur. **Make sure that the cable traps do not touch or bind the cables.**

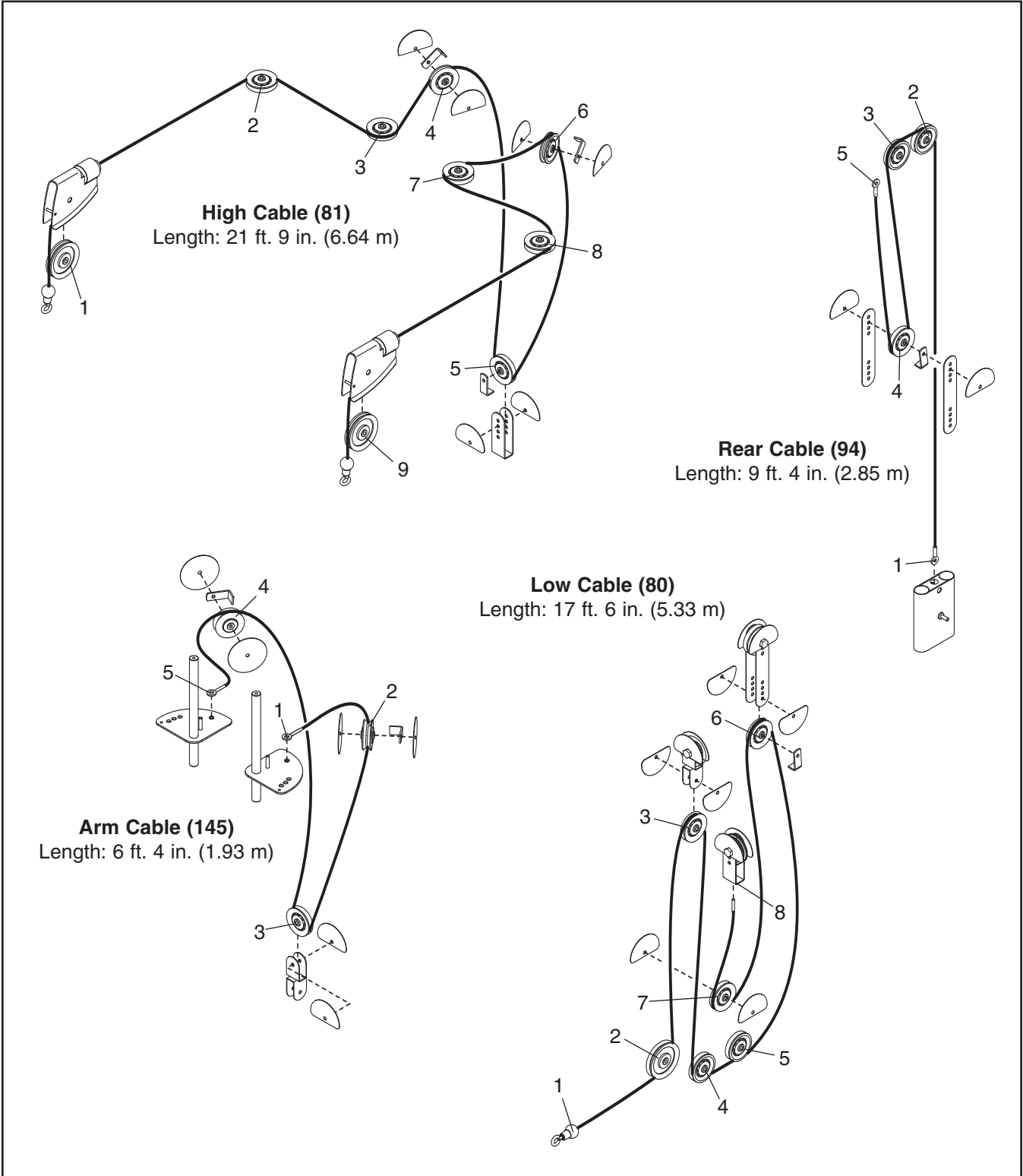

---

# EXERCISE GUIDELINES

## THE FOUR BASIC TYPES OF WORKOUTS

### Muscle Building

To increase the size and strength of your muscles, push them close to their maximum capacity. Your muscles will continually adapt and grow as you progressively increase the intensity of your exercise. You can adjust the intensity level of an individual exercise in two ways:

- by changing the amount of resistance used
- by changing the number of repetitions or sets performed. (A “repetition” is one complete cycle of an exercise, such as one sit-up. A “set” is a series of repetitions.)

The proper amount of resistance for each exercise depends upon the individual user. You must gauge your limits and select the amount of resistance that is right for you. Begin with 3 sets of 8 repetitions for each exercise you perform. Rest for 3 minutes after each set. When you can complete 3 sets of 12 repetitions without difficulty, increase the amount of resistance.

### Toning

You can tone your muscles by pushing them to a moderate percentage of their capacity. Select a moderate amount of resistance and increase the number of repetitions in each set. Complete as many sets of 15 to 20 repetitions as possible without discomfort. Rest for 1 minute after each set. Work your muscles by completing more sets rather than by using high amounts of resistance.

### Weight Loss

To lose weight, use a low amount of resistance and increase the number of repetitions in each set. Exercise for 20 to 30 minutes, resting for a maximum of 30 seconds between sets.

### Cross Training

Cross training is an efficient way to get a complete and well-balanced fitness program. An example of a balanced program follows:

- Plan strength training workouts on Monday, Wednesday, and Friday.
- Plan 20 to 30 minutes of aerobic exercise, such as running on a treadmill or riding on an elliptical exerciser or exercise cycle, on Tuesday and Thursday.
- Rest from both strength training and aerobic exercise for at least one full day each week to give your body time to regenerate.

The combination of strength training and aerobic exercise will reshape and strengthen your body, plus develop your heart and lungs.

## PERSONALIZING YOUR EXERCISE PROGRAM

Determining the appropriate length of time for each workout, and the numbers of repetitions and sets to complete, is an individual matter. Avoid overdoing it during the first few months of your exercise program. Progress at your own pace and be sensitive to your body’s signals. If you experience pain or dizziness while exercising, stop immediately and cool down. Find out what is wrong before continuing. Remember that adequate rest and a proper diet are important factors in any exercise program.

### WARMING UP

Begin each workout with 5 to 10 minutes of stretching and light exercise to warm up. Warming up prepares your body for more strenuous exercise by increasing circulation, raising your body temperature and delivering more oxygen to your muscles.

### WORKING OUT

Each workout should include 6 to 10 different exercises. Select exercises for every major muscle group, emphasizing areas that you want to develop most. To give balance and variety to your workouts, vary the exercises from workout to workout.

Schedule your workouts for the time of day when your energy level is the highest. Each workout should be followed by at least one day of rest. Once you find the schedule that is right for you, stick with it.

### EXERCISE FORM

Maintaining proper form is an essential part of an effective exercise program. This requires moving through the full range of motion for each exercise, and moving only the appropriate parts of the body. Exercising in an uncontrolled manner will leave you feeling exhausted. On the exercise guide accompanying this manual you will find photographs showing the correct form for several exercises, and a list of the muscles affected. See the muscle chart on the next page to find the names of the muscles.

The repetitions in each set should be performed smoothly and without pausing. The exertion stage of each repetition should last about half as long as the return stage. Proper breathing is important. Exhale during the exertion stage of each repetition and inhale during the return stroke. Never hold your breath.

The repetitions in each set should be performed smoothly and without pausing. The exertion stage of each repetition should last about half as long as the return stage. Proper breathing is important. Exhale during the exertion stage of each repetition and inhale during the return stroke. Never hold your breath.

Rest for a short period of time after each set. The ideal resting periods are:

- Rest for three minutes after each set for a muscle building workout.
- Rest for one minute after each set for a toning workout.
- Rest for 30 seconds after each set for a weight loss workout.

Plan to spend the first couple of weeks familiarizing yourself with the equipment and learning the proper form for each exercise.

## COOLING DOWN

End each workout with 5 to 10 minutes of stretching. Include stretches for both your arms and legs. Move slowly as you stretch and do not bounce. Ease into each stretch gradually and go only as far as you can without strain. Stretching at the end of each workout is an effective way to increase flexibility.

## STAYING MOTIVATED

For motivation, keep a record of each workout. List the date, the exercises performed, the resistance used, and the numbers of sets and repetitions completed. Record your weight and key body measurements at the end of every month. The key to achieving the greatest results is to make exercise a regular and enjoyable part of your everyday life.

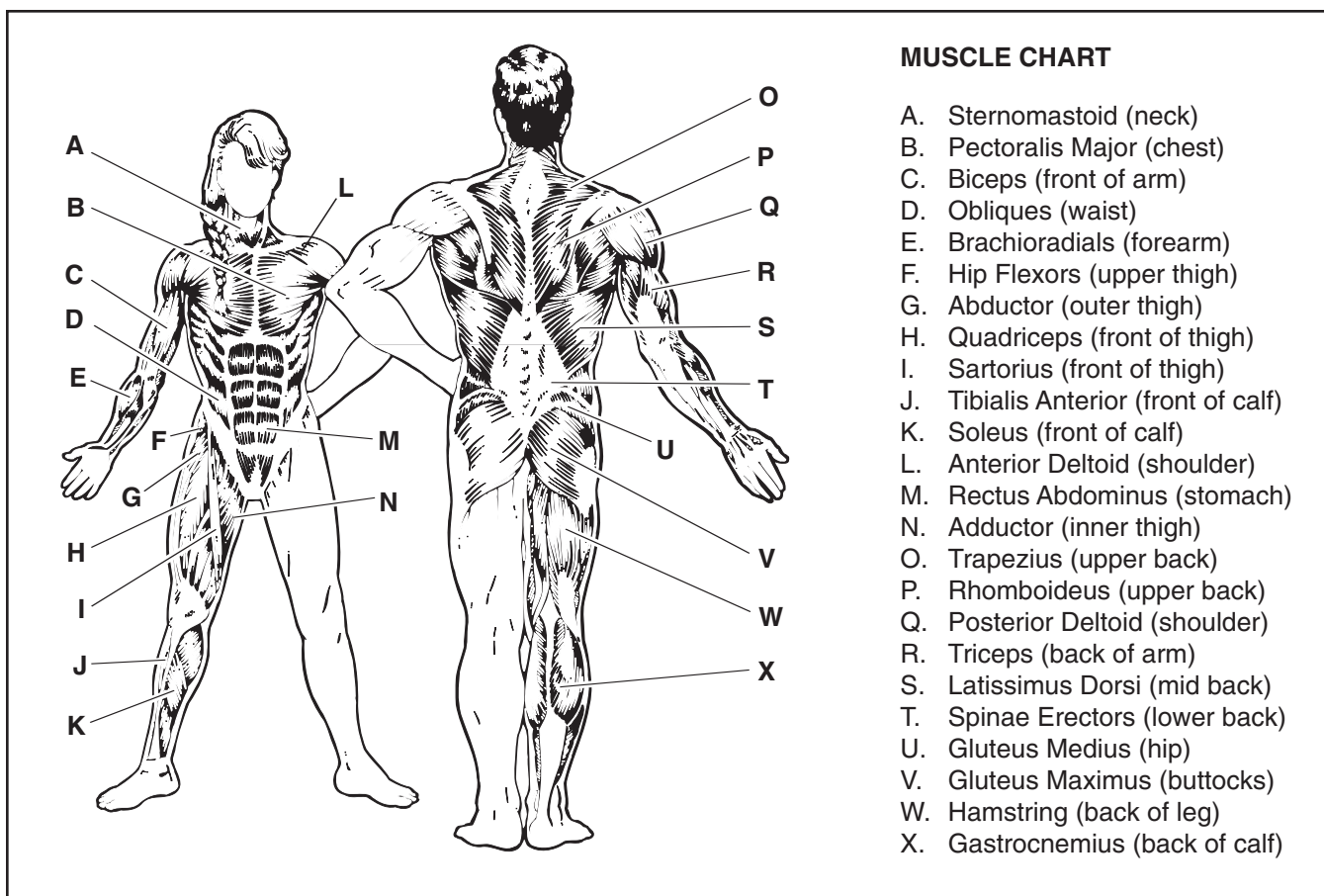

## MUSCLE CHART

- A. Sternomastoid (neck)
- B. Pectoralis Major (chest)
- C. Biceps (front of arm)
- D. Obliques (waist)
- E. Brachioradialis (forearm)
- F. Hip Flexors (upper thigh)
- G. Abductor (outer thigh)
- H. Quadriceps (front of thigh)
- I. Sartorius (front of thigh)
- J. Tibialis Anterior (front of calf)
- K. Soleus (front of calf)
- L. Anterior Deltoid (shoulder)
- M. Rectus Abdominus (stomach)
- N. Adductor (inner thigh)
- O. Trapezius (upper back)
- P. Rhomboideus (upper back)
- Q. Posterior Deltoid (shoulder)
- R. Triceps (back of arm)
- S. Latissimus Dorsi (mid back)
- T. Spinae Erectors (lower back)
- U. Gluteus Medius (hip)
- V. Gluteus Maximus (buttocks)
- W. Hamstring (back of leg)
- X. Gastrocnemius (back of calf)

<b>MONDAY</b> Date: _____ /   /	<b>EXERCISE</b>	<b>WEIGHT</b>	<b>SETS</b>	<b>REPS</b>

---

**TUESDAY**      **AEROBIC EXERCISE**  
 Date: \_\_\_\_\_  
 /   /

<b>WEDNESDAY</b> Date: _____ /   /	<b>EXERCISE</b>	<b>WEIGHT</b>	<b>SETS</b>	<b>REPS</b>

---

**THURSDAY**      **AEROBIC EXERCISE**  
 Date: \_\_\_\_\_  
 /   /

<b>FRIDAY</b> Date: _____ /   /	<b>EXERCISE</b>	<b>WEIGHT</b>	<b>SETS</b>	<b>REPS</b>

Make photocopies of this page for scheduling and recording your workouts.

# PART LIST—Model No. GGBE8057.0

R0607A

Key No.	Qty.	Description	Key No.	Qty.	Description
1	1	Bench Frame	51	1	Backrest Support Spacer
2	1	Rear Leg	52	2	Roller Spacer
3	1	Front Leg	53	2	Seat Carriage Roller
4	1	Leg Lever	54	2	13mm x 63mm Spacer
5	1	Curl Bar Frame	55	2	Seat Carriage Bushing
6	1	Seat Carriage	56	1	Seat Knob
7	2	Backrest Support	57	2	Pulley Handle
8	1	Backrest Frame	58	1	Lat Bar
9	1	Seat Frame	59	2	Lat Bar Handgrip
10	1	Curl Post	60	1	Lat Bar Connector
11	2	Front Upright	61	2	38mm Round Inner Cap
12	2	Rear Upright	62	2	Lat Bar Insert
13	1	Center Upright	63	2	Cable Clip
14	1	Base	64	1	Ankle Strap
15	1	Foot Plate	65	1	Row Bar
16	2	Base Foot	66	2	25mm Round Inner Cap
17	1	Top Frame	67	6	Weight Storage Tube
18	1	Weight Carriage Frame	68	9	48mm x 2mm Round Inner Cap
19	1	Weight Carriage	69	1	Butterfly Backrest
20	1	Weight Carriage Base	70	2	Trunnion
21	2	Weight Carriage Guide	71	4	Swivel Bracket Bearing
22	1	Left Arm	72	2	Swivel Bracket Spacer
23	1	Right Arm	73	8	Bracket Retainer
24	1	Right Adjustment Bracket	74	16	Small Pulley
25	1	Left Adjustment Bracket	75	2	“V”-pulley
26	2	Weight Rest	76	4	Full Pulley Guard
27	2	Weight Rest Pad	77	2	Large Cable Trap
28	4	Upright Pin/Tether	78	4	Floor Guard
29	2	Weight Spotter	79	2	M4 x 30mm Self-tapping Screw
30	2	Weight Spotter Pad	80	1	Low Cable
31	2	Swivel Bracket	81	1	High Cable
32	1	Backrest	82	4	63.5mm Round Inner Cap
33	1	Seat	83	2	Arm Handgrip
34	1	Curl Pad	84	2	Arm Handgrip Cap
35	6	Foam Pad	85	2	Arm Knob
36	1	Curl Bar Pin/Tether	86	4	M10 Lock Washer
37	6	Pad Cap	87	8	Butterfly Bushing
38	2	Leg Lever Bushing	88	4	Bushing Cap
39	1	Leg Lever Bumper	89	1	Right Arm Pad
40	1	Curl Bar	90	1	Left Arm Pad
41	2	25mm x 2mm Round Inner Cap	91	16	Half Pulley Guard
42	1	50mm x 1.5mm Connecting Cap	92	2	Pulley Plate
43	1	75mm x 2mm Square Cap	93	5	Small Cable Trap
44	1	Post Knob	94	1	Rear Cable
45	1	75mm x 2mm Square Inner Cap	95	5	75mm Square Inner Cap
46	1	Transport Wheel	96	2	Weight Carriage Tube
47	4	50mm x 25mm Connecting Cap	97	2	Weight Bumper
48	4	Backrest Bushing	98	1	Double “U”-bracket
49	1	38mm x 50mm Connecting Cap	99	1	Headrest
50	1	50mm x 2mm Square Inner Cap	100	1	Weight Carriage Block

# PART LIST—Model No. GGBE8057.0

R0607A

Key No.	Qty.	Description	Key No.	Qty.	Description
101	2	38mm x 100mm Inner Cap	143	2	M8 x 22mm Shoulder Bolt
102	2	Barbell Adapter	144	2	M6 x 15mm Bolt
103	2	48mm x 3mm Round Inner Cap	145	1	Arm Cable
104	2	Barbell Carriage	146	1	M8 x 65mm Bolt
105	4	Bar Slide Bushing	147	22	M4 x 16mm Self-tapping Screw
106	4	Barbell Bushing	148	53	M10 Washer
107	2	Barbell Bumper	149	2	M6 Washer
108	4	38mm Barbell Spotter Bushing	150	2	M10 x 20mm Spacer
109	2	Barbell Spotter	151	24	M10 x 6.5mm Spacer
110	1	Right Spotter Hook	152	1	50mm Connecting Cap
111	2	Barbell Spotter Bumper	153	38	M10 Nylon Locknut
112	2	Barbell Guide	154	2	13mm x 15mm Spacer
113	1	Barbell	155	4	19mm x 6mm Spacer
114	1	Locking Bar	156	2	M6 Nylon Locknut
115	1	Left Spotter Hook	157	2	Adjustment Bracket Bushing
116	1	Front Leg Bumper	158	1	“U”-bracket
117	4	M10 x 100mm Screw	159	2	Pad Tube
118	1	M10 x 83mm Bolt Set	160	1	Weight Spacer
119	1	M10 x 95mm Bolt	161	4	Barbell Spotter Retainer
120	8	M4 x 20mm Self-tapping Screw	162	1	50mm x 1.5mm Square Inner Cap
121	4	M8 x 75mm Bolt	163	2	38mm x 100mm Outer Cap
122	10	M6 x 20mm Screw	164	3	M8 Washer
123	3	M10 x 165mm Bolt	165	3	Large Pulley
124	2	M10 x 90mm Bolt	166	2	M10 x 25mm Bolt
125	5	M10 x 48mm Bolt	167	1	63.5mm Square Inner Cap
126	2	M6 x 90mm Screw	168	2	Curl Yoke Bushing
127	13	M10 x 55mm Bolt	169	2	M10 x 25mm Spacer
128	4	M10 x 25mm Screw	170	11	M8 Nylon Locknut
129	2	M10 x 93mm Bolt	171	4	M10 Large Washer
130	14	M10 x 110mm Screw	172	1	M8 x 90mm Bolt
131	4	M10 x 155mm Screw	173	3	Cable Stop
132	2	Weight Clip	174	3	Cable Eyelet
133	2	M10 x 60mm Bolt	175	1	Cabling Rod
134	4	M10 x 30mm Screw	176	1	Chain
135	2	Large Washer	177	3	M8 Jam Nut
136	2	M8 x 40mm Bolt	178	1	Curl Bar Spacer
137	1	M10 x 65mm Bolt	179	2	Spring Retainer
138	2	Weight Carriage Bumper	180	2	38mm x 100mm Large Outer Cap
139	4	Weight Carriage Bushing	*	-	User's Manual
140	7	M10 x 45mm Bolt	*	-	Exercise Guide
141	4	M6 x 16mm Screw	*	-	Grease Packet
142	2	M6 x 20mm Chamfer Screw	*	-	Hex Key

Note: Specifications are subject to change without notice. See the back cover of this manual for information about ordering replacement parts. \*These parts are not illustrated.



# EXPLODED DRAWING A—Model No. GGBE8057.0

R0607A

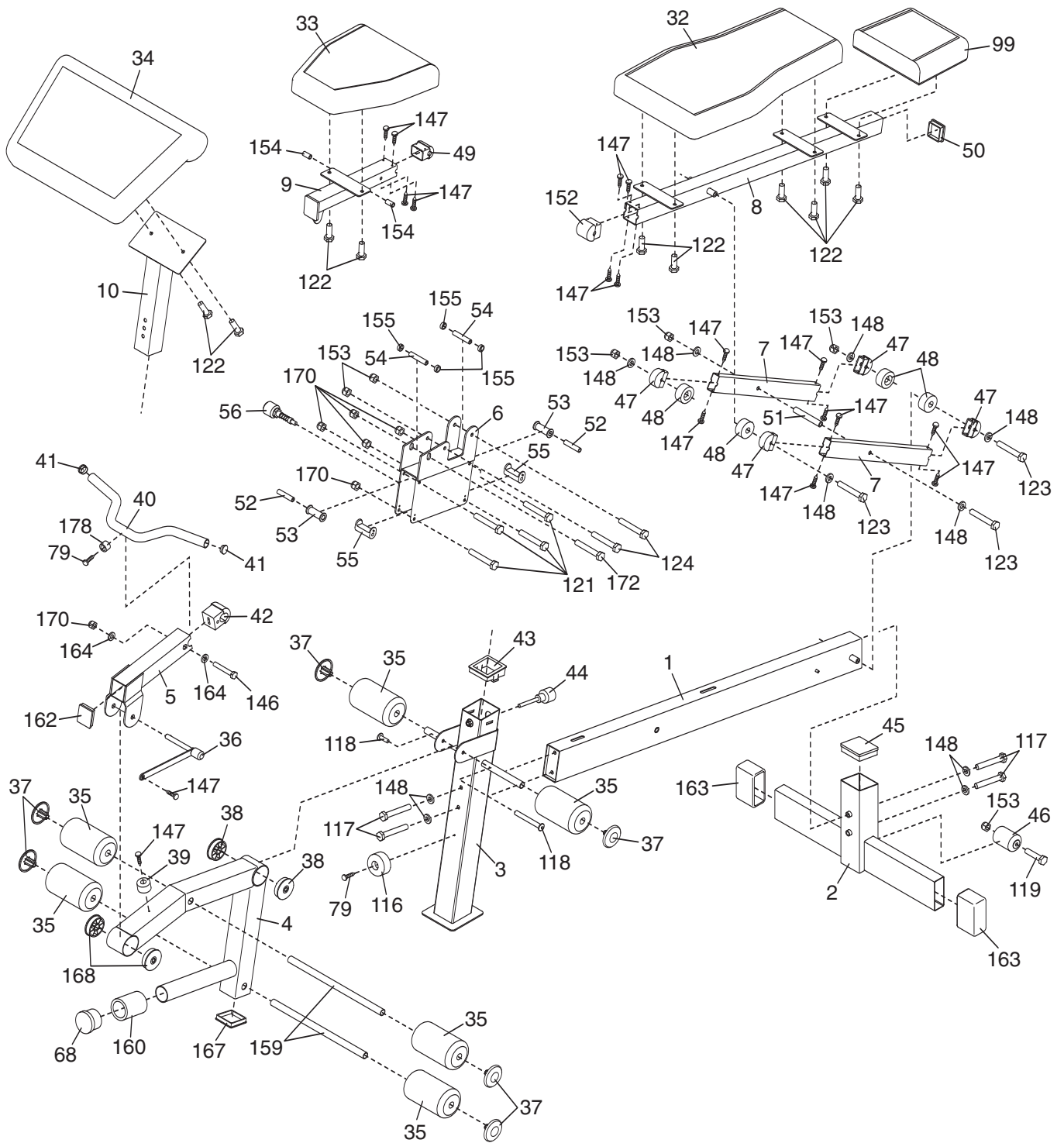



# EXPLODED DRAWING B—Model No. GGBE8057.0

R0607A

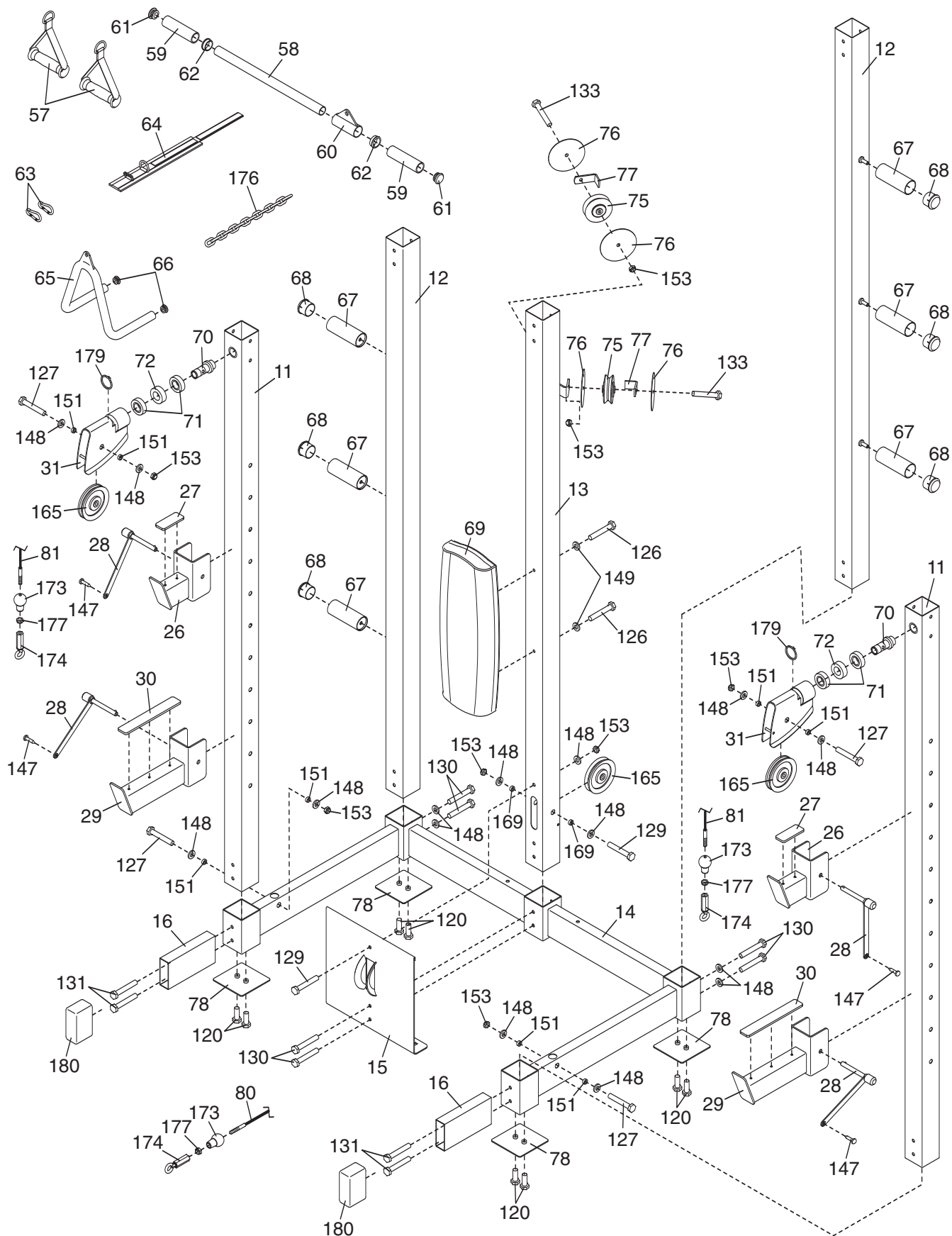

# EXPLODED DRAWING C—Model No. GGBE8057.0

R0607A

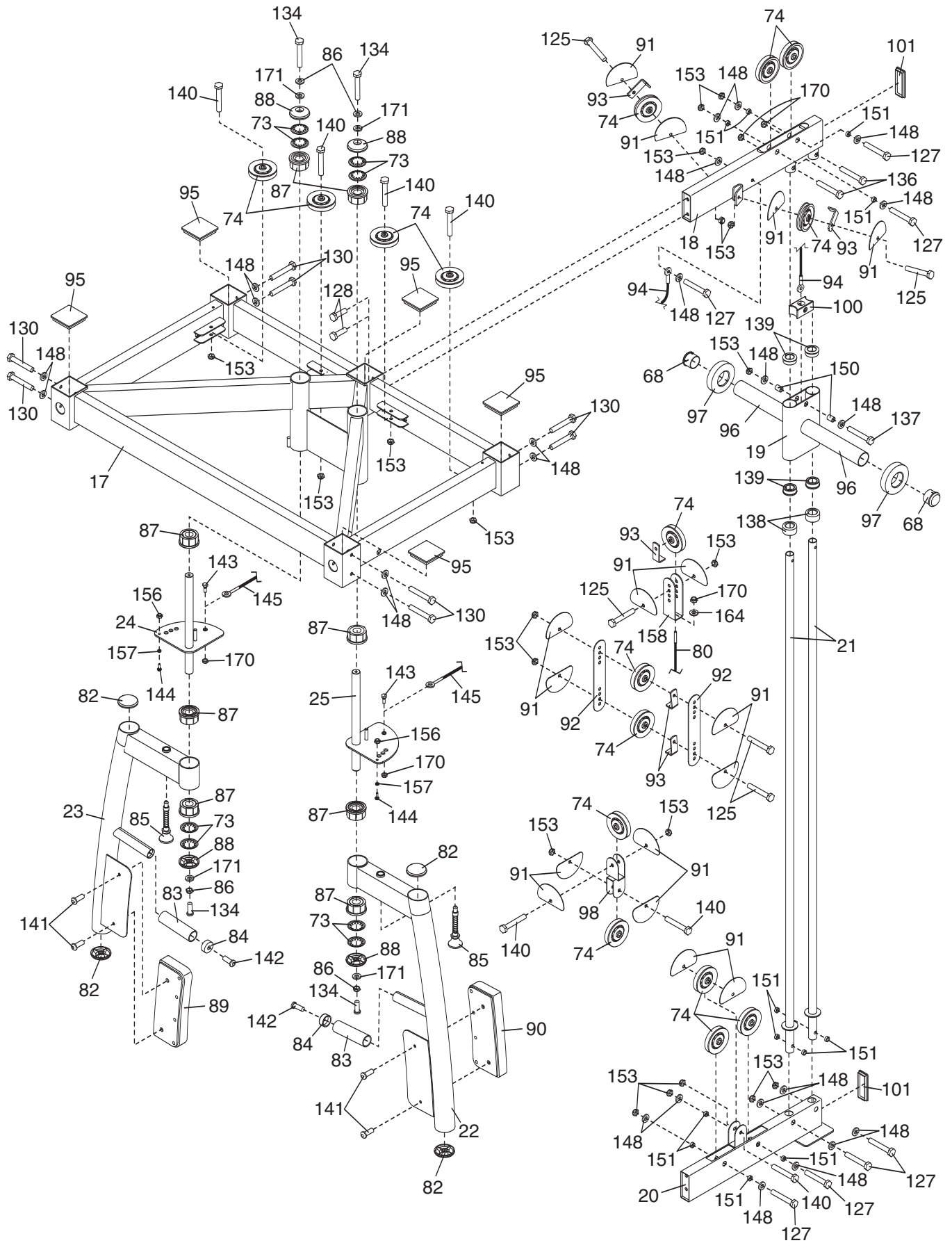

# EXPLODED DRAWING D—Model No. GGBE8057.0

R0607A

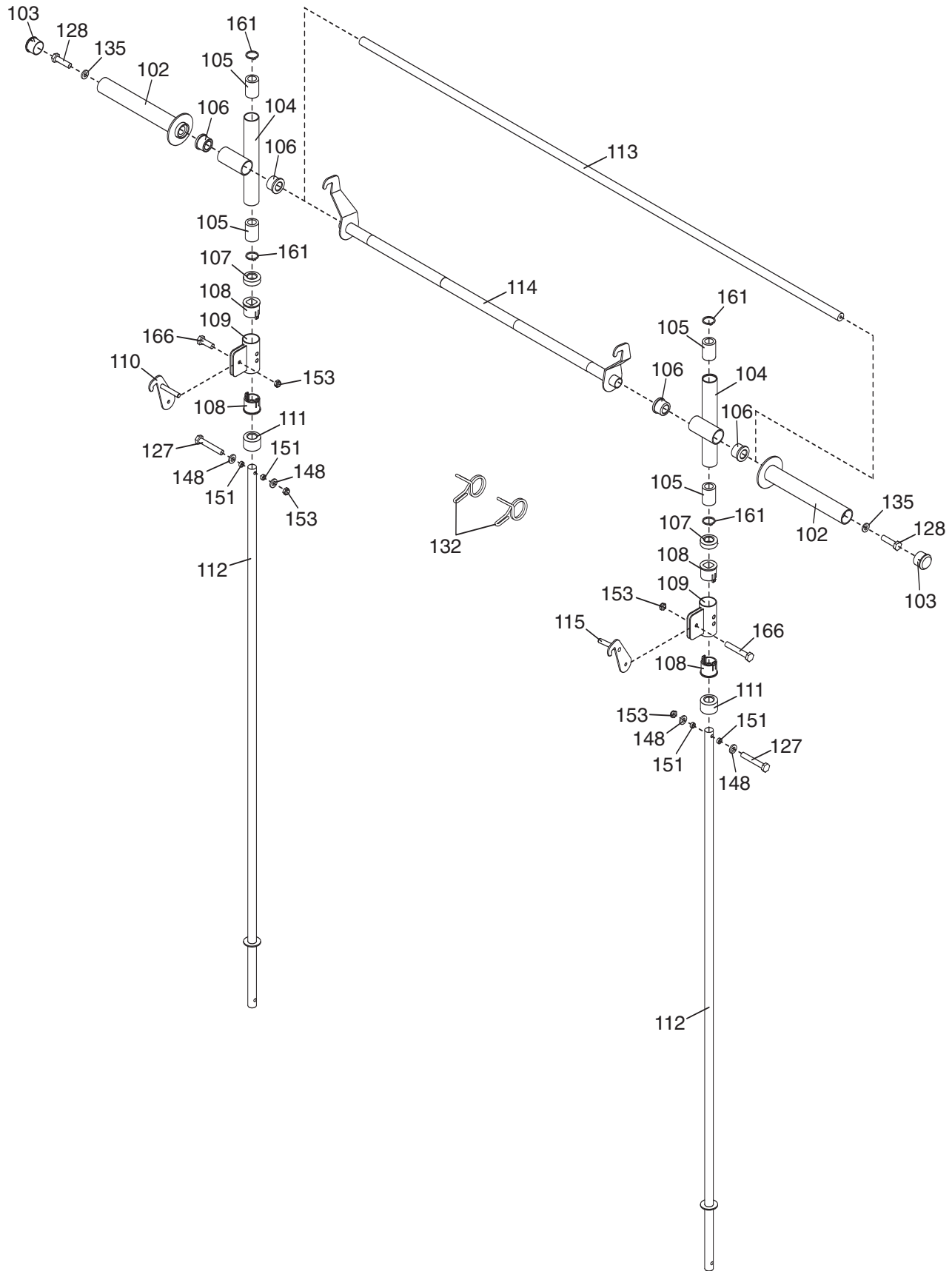

---

# ORDERING REPLACEMENT PARTS

To order replacement parts, please see the front cover of this manual. To help us assist you, be prepared to provide the following information when contacting us:

- the model number and serial number of the product (see the front cover of the manual)
- the name of the product (see the front cover of this manual)
- the key number and description of the part(s) (see the PART LIST and the EXPLODED DRAWING near the end of this manual)

## LIMITED WARRANTY

ICON Health & Fitness, Inc. (ICON) warrants this product to be free from defects in workmanship and material, under normal use and service conditions, for a period of ninety (90) days from the date of purchase. This warranty extends only to the original purchaser. ICON's obligation under this warranty is limited to replacing or repairing, at ICON's option, the product through one of its authorized service centers. All repairs for which warranty claims are made must be pre-authorized by ICON. If the product is shipped to a service center, freight charges to and from the service center will be the customer's responsibility. For in-home service, the customer will be responsible for a minimal trip charge. This warranty does not extend to any product or damage to a product caused by or attributable to freight damage, abuse, misuse, improper or abnormal usage or repairs not provided by an ICON authorized service center; products used for commercial or rental purposes; or products used as store display models. No other warranty beyond that specifically set forth above is authorized by ICON.

ICON is not responsible or liable for indirect, special or consequential damages arising out of or in connection with the use or performance of the product or damages with respect to any economic loss, loss of property, loss of revenues or profits, loss of enjoyment or use, costs of removal or installation or other consequential damages of whatsoever nature. Some states do not allow the exclusion or limitation of incidental or consequential damages. Accordingly, the above limitation may not apply to you.

The warranty extended hereunder is in lieu of any and all other warranties and any implied warranties of merchantability or fitness for a particular purpose is limited in its scope and duration to the terms set forth herein. Some states do not allow limitations on how long an implied warranty lasts. Accordingly, the above limitation may not apply to you.

This warranty gives you specific legal rights. You may also have other rights which vary from state to state.

**ICON HEALTH & FITNESS, INC., 1500 S. 1000 W., LOGAN, UT 84321-9813**